

SL20GH

Electric pallet truck

电动托盘搬运车

Parts list 零件目录

20250401 V09

PARTS ORDERING INSTRUCTIONS

HOW TO ORDER

When you order, supply the part number, quantity, model and serial numbers of your machine. Supplying this information will assure prompt, efficient handing of your order.

Since your dealer carries many parts in stock and maintains up-to-date prices on all parts, he will be able to process your order immediately. If, for some reason, the part is not in stock, he will order it from the factory. In either event, he maintains a current file of service manuals, which give all available parts ordering or technical information.

WHERE TO ORDER

Always order parts from the dealer who sold you your truck. If it is necessary for the dealer to order parts from the factory, he is able to get prompt service for you. Parts are shipped in accordance with shipping instructions given on the order.

INSTRUCTIONS FOR RETURNING PARTS

Under NO CIRCUMSTANCES will parts be accepted at the factory for credit without prior approval. We cannot accept responsibility for parts returned without authorization.

If you have some parts which must be returned, contact your dealer. If he believes parts should be returned, he will arrange for authorization to return the parts.

CHANGES

When changes are made to the machine, revised pages for this manual will be issued. These pages must be inserted in your parts manual as soon as they are received.

Failure to keep your parts manuals up to date will result in confusion and may cause you to order wrong parts.

零件订购说明

如何订购

当您订购的时候，您需要提供叉车零件的编号，数量，型号和序列号。提供这些信息能够保证您的订购更加的高效。

因为您的经销商有很多零件的存货，而且需要保持所有零件的价格是最新的，所以他会尽快地处理您的订购需求。假如因为某些原因，存货中没有这个零件，那么他会从公司订货。无论怎样的情况，他手里都会有一份服务手册文件，它能提供所有可用的零件的订购信息或者技术信息。

订购地点

当您需要订购零件时，请到销售给您叉车的经销商那里订购。如果经销商有必要从公司订购零件，他能为您提供快捷的服务。根据您的订购信息，零件和它对应的操作说明会一起装好。

零件的退还说明

一般情况下，因为信用的关系，退还的零件没有事先的同意，是不会被公司认可的。我们不会对没有经过授权但退还过来的零件负责。

如果您有一些零件一定要退还，请联系您的经销商。若经销商确认零件可以退还，则其会安排授权要退还的零件。

技术修改

当叉车技术有修改时，这本手册的修正页会重新发行。当您拿到这些修正页时，您一定要立即把它们插入到您的零件手册中。若没有及时的更新您的零件手册，则可能会导致您订购、维护等方面的错误。

GENERAL INFORMATION

INDEX

This parts manual is arranged for easy identification of parts .The index at the front of the catalog gives location of major groups and assemblies.

PART LIST

The Item, describes the item on the Figure you are looking at. The Part No. is a numerical description of the item and the part ordering number. The Description is a description of the part number in alphabetical form. The Qty is the quantity used on the machine. The Applied Date is a description when the part is applicable.The Remark is the explanation of the part for a supplement such as the model the capability, the characteristic etc.

HOW TO READ PARTS MANUAL

HELP 1:

Item	Part No	Description	Qty	Applied Date	Remark
------	---------	-------------	-----	--------------	--------

A →

1		02.XDC.3556	Battery	1		24V/20AH
1		02.XDC.3557	Battery	1		24V/30AH
1		02.XDC.3558	Battery	1		24V/40AH
2		03.0132	Screw M5×8	5		

B →

7		03.0245	Nut M12	2		
8		03.04790	Spring	2		
9	01	30.01.6685	Wheel Frame	1	-210125	
9	02	40.11.048	Wheel Frame	1	210125-	

C →

6		02.KSCX.0001	Cover	1		
7		03.0243	Nut M10	2		Cancel
8		40.11.040	Roller	2		
9		03.1088	Bolt M10×60	2		

D →

3		33.054.0001	Frame (550)	1		
3		33.054.0002	Frame (685)	1		
4		03.02393	Screw M6×16	6		
5		40.18.005	Shaft (550)	1		
5		40.15.044	Shaft (685)	1		

E →

6		33.036.0007	Push Rod Welding	2		For 1800Kg
7		03.0691	Bushing Φ19×Φ16×15	4		
8		03.0305	Round Pin Φ5×30	10		

A:The part of Index 1 is Optional.

B:The part of Index 9 has an Applicability, because it's our policy to constantly improve our products.

C:The part of Index 7 indicates that the part is cancelled. Note the version number when ordering.

D:The part of Index 3 indicates that the frame welds have different specifications, 550 or 685 indicates the outer width of the forks. Index 5 indicates the parts used for the outer width of the forks.

E:The part of Index 6 indicates that the part is used for model with load capacity of 1800KG.

1. Record by time

- 210125 : Ending on January 25, 2021.

210125- : Beginning on January 25, 2021.

2. Record by serial number

01 : Ending at 01

02 : Starting at 02

概要 目录

将零件目录分组成几个易识别的部分，并把主要结构和总成放置在索引目录中。

零件明细表

Item 描述的是在插图上，您想要找的项目。**Part No.**是零件的一系列描述和它的订购号码。**Description** 是用文字的形式描述零件的号码。**Qty** 代表的是零件在搬运车上使用的数量。**Applied Date** 表示的是零件适用的时间范围。**Remark** 是用来补充说明零件信息(例如车型、性能和特征等)。

怎么读取零件明目录

帮助 1:

Item 序号	Part No 代码	Description 名称	Qty 数量	Applied Date 适用日期	Remark 备注	
A →	1	02.XDC.3556	Battery 锂电池	1		24V/20AH
	1	02.XDC.3557	Battery 锂电池	1		24V/30AH
	1	02.XDC.3558	Battery 锂电池	1		24V/40AH
	2	03.0132	Screw M5×8 螺钉	5		
B →	7	03.0245	Nut M12 螺母	2		
	8	03.04790	Spring 弹簧	2		
	9	01 30.01.6685	Wheel Frame 轮架	1	-210125	
	9	02 40.11.048	Wheel Frame 轮架	1	210125-	
C →	6	02.KSCX.0001	Cover 前盖板	1		
	7	03.0243	Nut M10 螺母	2		Cancel/取消
	8	40.11.040	Roller 滚子	2		
	9	03.1088	Bolt M10×60 螺栓	2		
D →	3	33.054.0001	Frame(550) 车架	1		
	3	33.054.0002	Frame(685) 车架	1		
	4	03.02393	Screw M6×16 螺钉	6		
	5	40.18.005	Shaft(550) 支撑轴	1		
	5	40.15.044	Shaft(685) 支撑轴	1		
E →	6	33.036.0007	Push Rod Welding 推杆	2		For 1800Kg
	7	03.0691	BushingΦ19×Φ16×15 复合套	4		
	8	03.0305	Round PinΦ5×30 弹性圆柱销	10		

A: 序号 1 表示该零件有几个品种可供您的选择。

B: 序号 9 表示该零件有一个适用的时间范围。这是因为我们在不断地进行产品的升级。

C: 序号 7 表示该零件取消，订购时注意版本号。

D: 序号 3 表示车架焊接体有不同的规格，550 或 685 表示货叉的外宽。序号 5 表示配用于货叉外宽的零部件。

E: 序号 6 表示该零件配用载重 1800KG 车型。

1. 用时间记录

- **210125** : 截止到 2021 年 01 月 25 日

210125- : 起始于 2021 年 01 月 25 日

2. 用序列号记录

01 : 截止序列号 01

02 : 起始序列号 02

帮助 2:

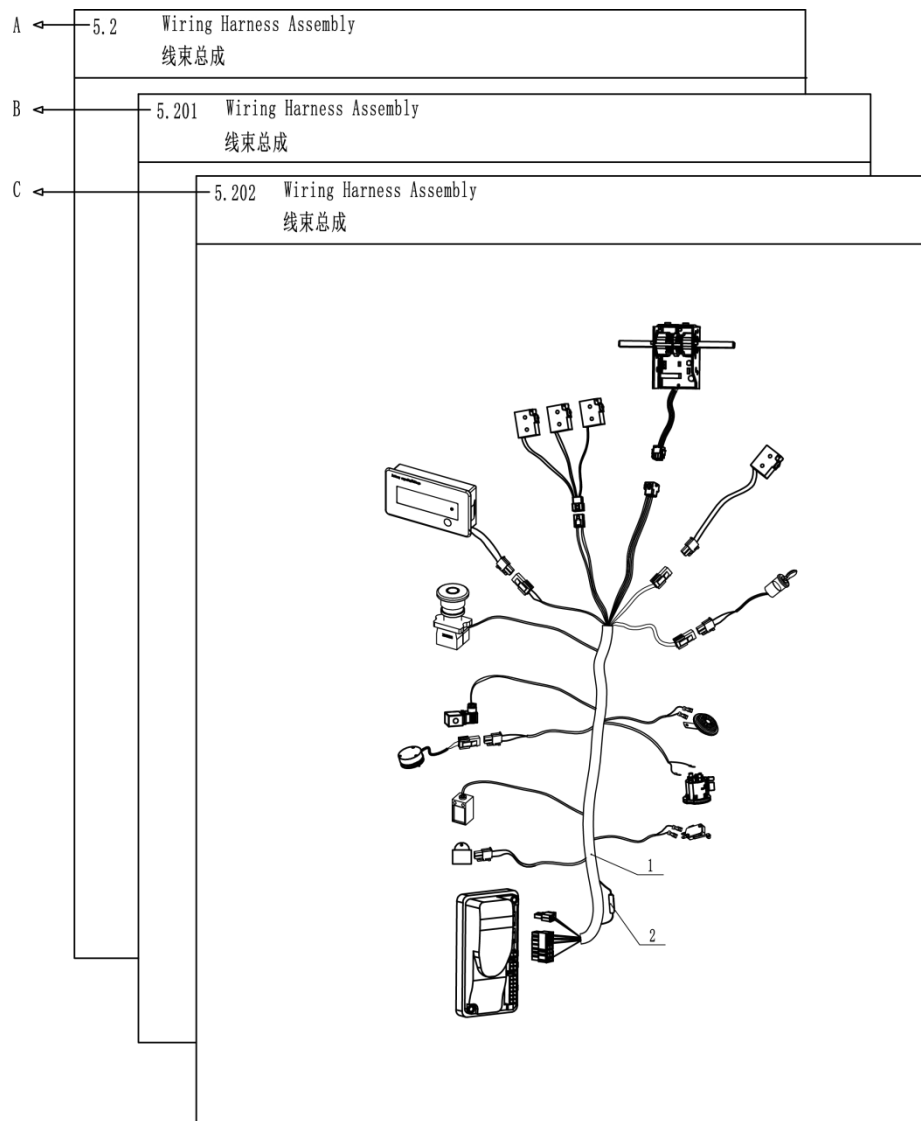

A: 章节 5.2 表示原始版本;

B: 章节 5.201 表示在原始版本 (章节 5.2) 上零件有所变更;

C: 章节 5.202 表示在变更版本 (章节 5.201) 上零件有所变更。

当您订购零件时, 请根据每个版本中零件的适用时间来判断您所选购车型的零件信息。

Index 目录

1. Frame System 车身系统

1.1 Frame System 车架总成.....	1
1.202 Distribution Box Assembly 配电箱总成.....	2
1.301 Connecting Rod Assembly 连杆组件（双轮）.....	3
1.401 Connecting Rod Assembly 连杆组件（单轮）.....	5
1.501 Cover Assembly 外罩总成.....	6

2. Driving System 驱动系统

2.101 Driving Assembly 驱动总成.....	7
2.201 Caster Assembly 平衡轮组件.....	9

3. Operating System 操作系统

3.101 Handle Assembly 手柄总成.....	11
3.2 Control Pod Assembly I 手柄头总成 I	12
3.3 Control Pod Assembly II 手柄头总成 II	14

4. Hydraulic System 液压系统

4.102 Hydraulic Assembly 液压总成.....	16
4.2 Power Unit Assembly 动力单元组件.....	17

5. Electric System 电气系统

5.102 Electric Assembly (DC) 电气总成 (直流)	18
5.202 Electric Assembly (AC) 电气总成 (交流)	20
5.4 Wiring Harness Assembly 1212S-2501 线束总成 1212S-2501.....	23
5.5 Wiring Harness Assembly D3-2111 线束总成 D3-2111 (圆形电量表)	24
5.6 Wiring Harness Assembly D3-2111 线束总成 D3-2111.....	25
5.7 Wiring Harness Assembly F2-A 线束总成 F2-A.....	26
5.8 Cable Assembly Lead acid 电缆总成 铅酸.....	27
5.9 Cable Assembly Li 电缆总成 锂电.....	28
5.10 Cable Assembly F2-A Lead acid 电缆总成 F2-A 铅酸.....	29
5.11 Cable Assembly F2-A Li 电缆总成 F2-A 锂电.....	30

修订记录

版 本	修订人	更改单编号	修订事项
20200316 V01	蒋连杰		首次发布；
20200513 V02	蒋连杰		①：3.2 新增大手柄图；
20200724 V03	蒋连杰		①：3.3 新增手柄组件（智能）图； ②：3.4 新增手柄头总成（智能）图；
20200817 V04	蒋连杰		①：5.101 取消代码 02.01.22136 橡胶垫块、代码 30.16.0016 橡胶垫板、代码 30.16.0037 电瓶挡板； ②：5.101 新增代码 30.16.0041 插板、代码 30.09.0005 橡胶垫、代码 30.16.0046 电瓶挡板；
20210413 V05	沈培彦		①：版本格式整体调整；
20240307 V06	高艾鑫	No. 2024052	①：版本格式整体调整； ②：1.301 中新增 20201001552 推杆安装套 2 个；新增 30301220002 螺母 2 个；55501000059 推杆更改为 55501000215 推杆； ③：1.401 中新增 20201001552 推杆安装套 2 个；新增 30301220002 螺母 2 个；55501000059 推杆更改为 55501000215 推杆；
20250108 V07	莫敏萍	No. 2024249	1.202 中 52101000021 驱动总成更换为 52101000116 驱动总成；新增 52101000032 驱动总成； 2.101 中 52101000021 驱动总成更换为 52101000116 驱动总成；新增 52101000032 驱动总成；新增 70401000115 交流电机；30601050004 平键销更换为 30601050006 平键销；52201150006 传动齿轮更换为 52201150011 传动齿轮；52202120004 被动斜齿轮更换为 52202120013 被动斜齿轮；30701017001 轴承更换为 30701017003 轴承；52105000054 齿轮箱更换为 52105000070 齿轮箱；
20250215 V08	莫敏萍	No. 2025021 No. 2025033	1.501 中新增 20201000695 配电箱盖； 4.101 中 40201000003 直接头更改为 40201140005 直接头； 5.102 中新增 70601000006 电量表；5.202 中新增 70601000006 电量表；

20250401 V09	莫敏萍	No. 2025086	1. 202 中 30201100024 螺钉更改为 30201100025 螺钉； 51231000029 平衡轮组件更改为 20301020001 平衡轮组件； 新增 30311100001 螺母 8 个； 2. 201 中 51231000029 平衡轮组件更改为 20301020001 平衡轮组件； 4. 102 中 40101140002 胶管更改为 40101140322 胶管；
--------------	-----	-------------	---

1.1 Frame System
车架总成

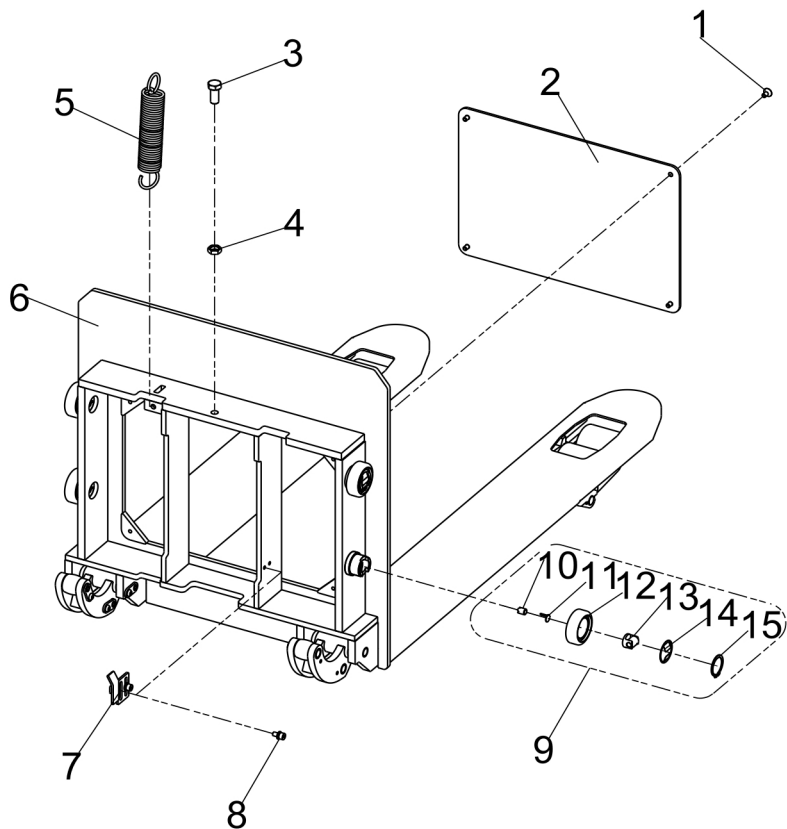

Item 序号	Part No. 代码	Description 名称	Qty 数量	Applied Date 适用日期	Remark 备注
1	30251080029	Screw M8×16 螺钉	4		03.0116
2	20201000669	Front Sealing Plate 前封板	1		30.01.6376
3	30101160006	Screw M16×35 螺钉	1		03.0639
4	30301160004	Nut M16 螺母	1		03.0285
5	50402000006	Spring 拉簧	1		03.0896
6	20101010223	Frame (550) 车架	1		
6	20101010150	Frame (685) 车架	1		
6	20101010956	Frame (550) 车架	1		双面托盘
6	20101010957	Frame (685) 车架	1		双面托盘
7	20101010148	Bracket 行程限位板	1		33.035.0007
8	30201080028	Screw M8×16 螺钉	2		
9	51101000006	Roller Assembly 组合滚轮	4		
10	51103000020	Screw 调节螺钉	4		
11	51103000019	Loose Proof Sheet 止松片	4		
12	51102000012	Roller 滚轮	4		02.01.3073
13	51103000018	Support 支架	4		
14	51103000017	Dust Sheet 防尘片	4		
15	30421400001	Circlip For Shaft Φ40 轴用挡圈	4		03.0070

1.202 Distribution Box Assembly
配电箱总成

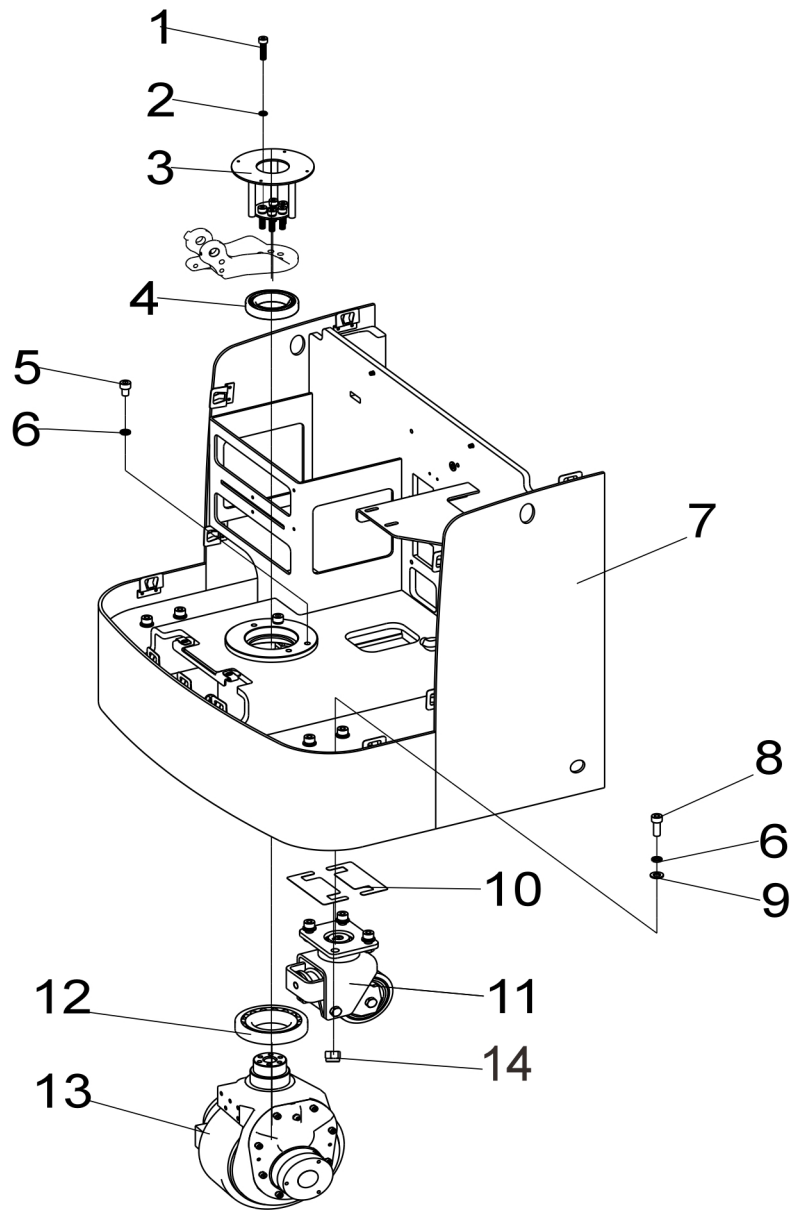

Item 序号	Part No. 代码	Description 名称	Qty 数量	Applied Date 适用日期	Remark 备注
1	30201080032	Screw M8×35 螺钉	6		03.0158
2	30411080002	Spring Washer Φ8 弹垫	6		03.0012
3	20101010146	Bracket 封罩安装架	1		33.035.0002
4	30701050004	Bearing 6010 轴承	1		03.90.018
5	30201100021	Screw M10×16 螺钉	2		03.0162
6	30411100002	Spring Washer Φ10 弹垫	10		03.0014
7	20101010145	Distribution Box 配电箱	1		33.035.0001
8 01	30201100024	Screw M10×30 螺钉	8	-250401	03.0166
8 02	30201100025	Screw M10×40 螺钉	8	250401-	
9	30401100002	Flat Washer Φ10 平垫	8		03.00513
10	20201000244	Plate 卡板	N		30.07.088
11 01	51231000029	Balance Wheel 平衡轮组件	2	-250401	81.004.031
11 02	20301020001	Balance Wheel 平衡轮组件	2	250401-	
12	30702060002	Bearing 30212 轴承	1		03.90.023
13 01	52101000021	Driving Assembly DC 驱动总成直流	1	-250108	02.QD.00833
13 02	52101000116	Driving Assembly DC 驱动总成直流	1	250108-	
13	52101000032	Driving Assembly AC 驱动总成交流	1	250108-	
14	30311100001	Nut M10 螺母	8	250401-	

1.301 Connecting Rod Assembly
连杆组件（双轮）

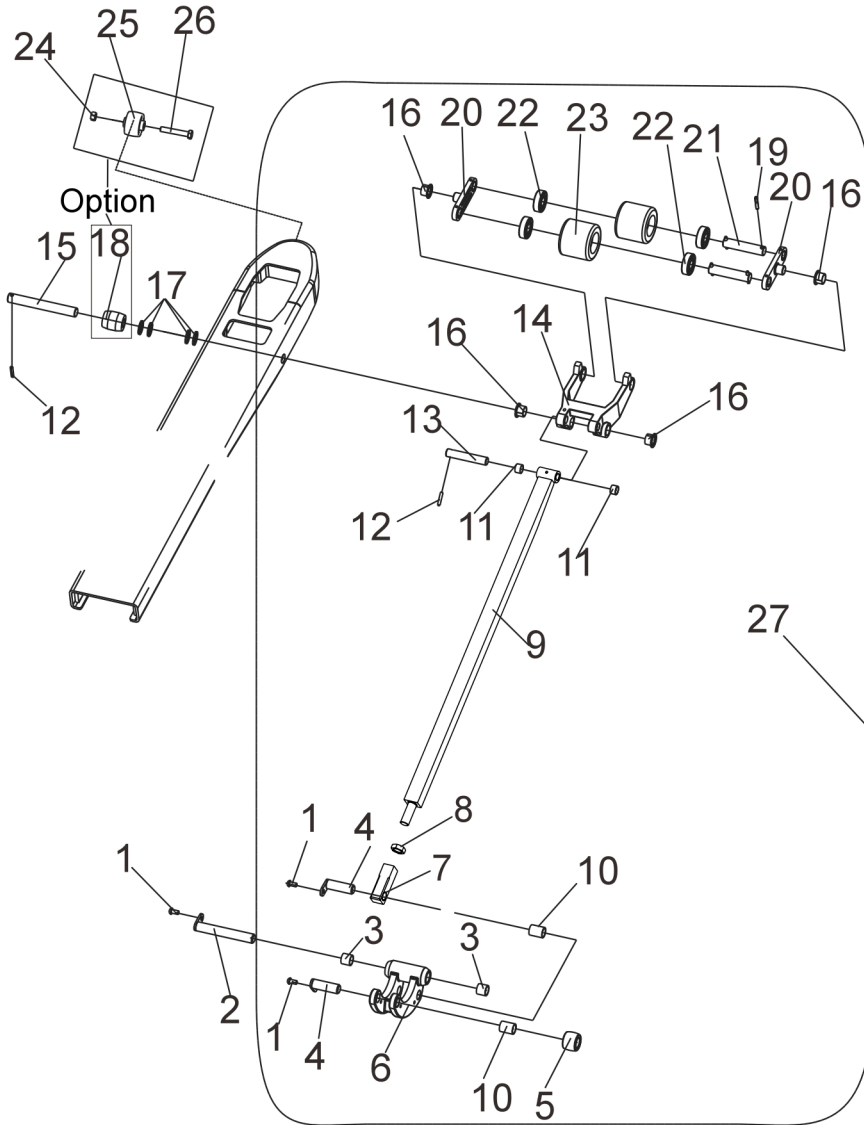

Item 序号	Part No. 代码	Description 名称	Qty 数量	Applied Date 适用日期	Remark 备注
A	20301020694	Connecting Rod Assembly 连杆组件	2		
1	30251080012	Screw M8×16 螺钉	6		03.0117
2	50105200013	Shaft 力臂架长轴	2		33.035.0006
3	54002000023	Bushing Φ23×Φ20×20 复合套	4		03.0450
4	50105200010	Shaft 力臂架短轴	4		33.025.0015
5	20201000138	Roller 滚子	2		30.10.0001
6	55101000002	Bracket 力臂架	2		30.16.0038
7	20201001552	Mounting Sleeves 推杆安装套	2	240530-	
8	30301220002	Nut M22 螺母	2	240530-	
9	01 55501000059	Push Rod 推杆	2	-240530	33.035.0009
9	02 55501000215	Push Rod 推杆	2	240530-	
10	54002000022	Bushing Φ23×Φ20×30 复合套	4		03.0450
11	54002000015	Bushing Φ20×Φ23×15 复合套	4		03.0457
12	30501050008	Cylindrical Pin Φ5×30 弹性圆柱销	6		03.0305
13	50101170006	Shaft 推杆轴	2		30.01.11871
14	55101000009	Block 力臂块	2		30.01.1061
15	50101200021	Shaft 力臂块轴	2		30.01.6419
16	54001000009	Bushing Φ23×Φ20×16.5 带肩复合套	8		03.0453
17	20201000075	Snap Ring 轮架止动环	8		30.09.0057
18	20201000531	Roller 退出滚子	2		30.01.1814
19	30501050003	Cylindrical Pin Φ5×35 弹性圆柱销	8		03.0303
20	51251000014	Connecting Plate 连板	4		30.01.1290
21	50101200040	Shaft 轮轴	4		30.01.3459
22	30701020007	Bearing 6204 轴承	8		03.90.057
23	51241000019	Wheel 承载轮	4		02.LZ.0119
24	30311100001	Nut M10 螺母	2		03.0243
25	51108000010	Roller 滚子	2		40.11.040-2
26	30101100049	Bolt M10×65 螺栓	2		03.0383

1.401 Connecting Rod Assembly
 连杆组件（单轮）

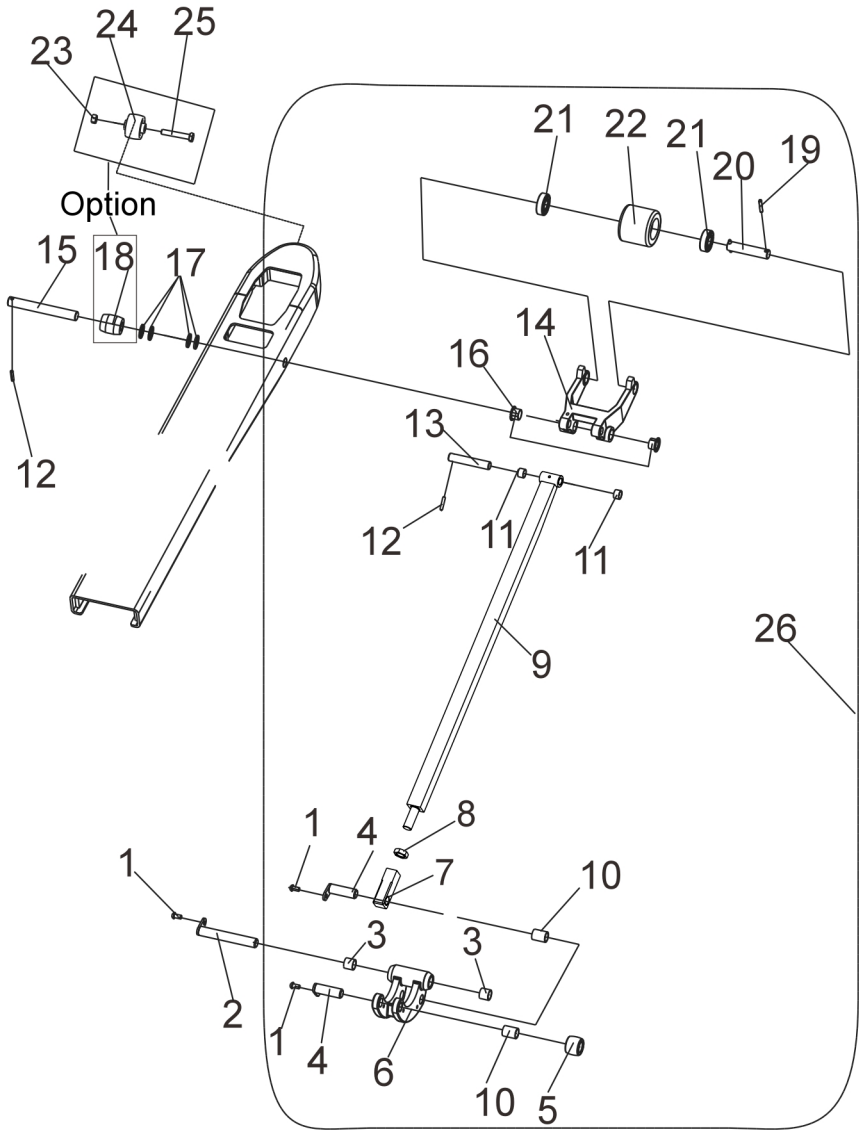

Item 序号	Part No. 代码	Description 名称	Qty 数量	Applied Date 适用日期	Remark 备注
A	20301020702	Connecting Rod Assembly 连杆组件	2		
1	30251080012	Screw M8×16 螺钉	6		03.0117
2	50105200013	Shaft 力臂架长轴	2		33.035.0006
3	54002000023	Bushing Φ23×Φ20×20 复合套	4		03.0450
4	50105200010	Shaft 力臂架短轴	4		33.025.0015
5	20201000138	Roller 滚子	2		30.10.0001
6	55101000002	Bracket 力臂架	2		30.16.0038
7	20201001552	Mounting Sleeves 推杆安装套	2	240530-	
8	30301220002	Nut M22 螺母	2	240530-	
9	01 55501000059	Push Rod 推杆	2	-240530	33.035.0009
9	02 55501000215	Push Rod 推杆	2	240530-	
10	54002000022	Bushing Φ23×Φ20×30 复合套	4		03.0450
11	54002000015	Bushing Φ20×Φ23×15 复合套	4		03.0457
12	30501050008	Cylindrical Pin Φ5×30 弹性圆柱销	6		03.0305
13	50101170006	Shaft 推杆轴	2		30.01.11871
14	55101000004	Block 力臂块	2		30.01.1061
15	50101200021	Shaft 力臂块轴	2		30.01.6419
16	54001000009	Bushing Φ23×Φ20×16.5 带肩复合套	4		03.0453
17	20201000075	Snap Ring 轮架止动环	8		30.09.0057
18	20201000531	Roller 退出滚子	2		30.01.1814
19	30501050003	Cylindrical Pin Φ5×35 弹性圆柱销	2		03.0303
20	50101200032	Shaft 轮轴	2		30.01.3459
21	30701020007	Bearing 6204 轴承	4		03.90.057
22	51241000133	Wheel 承载轮	2		02.LZ.0119
23	30311100001	Nut M10 螺母	2		03.0243
24	51108000010	Roller 滚子	2		40.11.040-2
25	30101100049	Bolt M10×65 螺栓	2		03.0383
26	20301020703	Twin Wheel Frames 单轮连杆轮架	2		

1.501 Cover Assembly
外罩总成

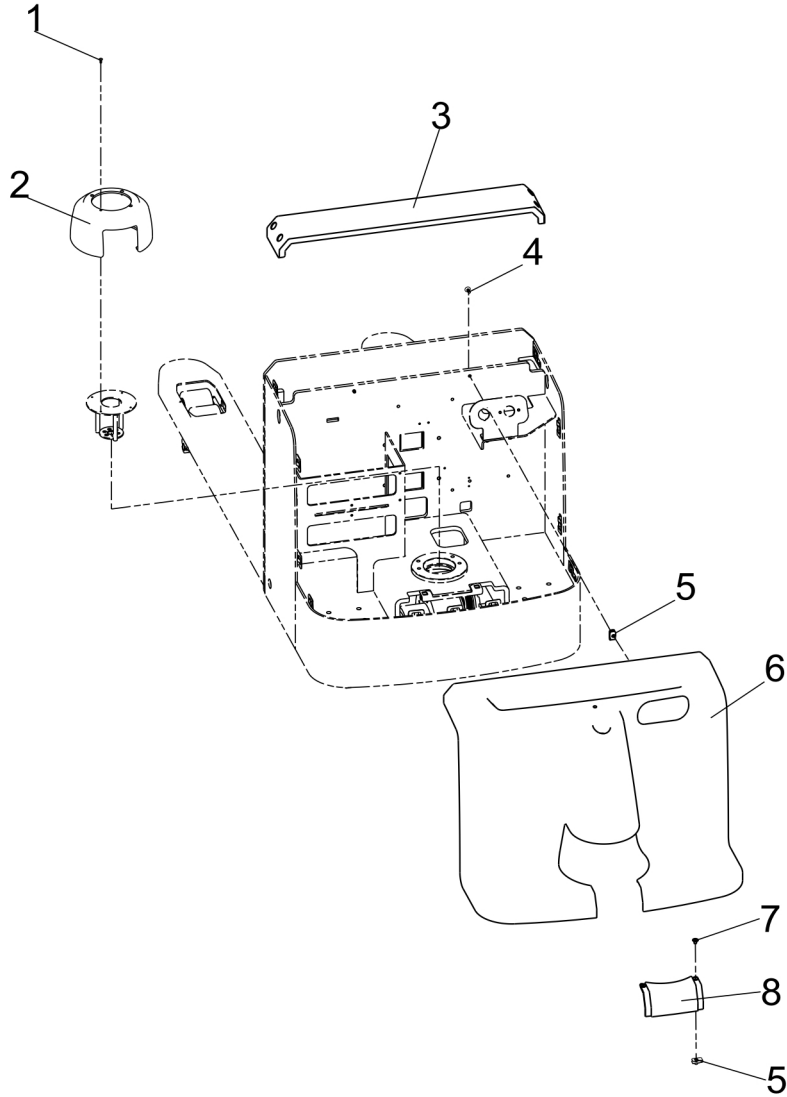

Item 序号	Part No. 代码	Description 名称	Qty 数量	Applied Date 适用日期	Remark 备注
1	30211040013	Screw M4×10 螺钉	4		03.0230
2	54302000168	Handle Cover 手柄罩	1		02.FGJ.3413
3	20201000680	Cover 前盖板	1		30.01.6459
4	30211060008	Screw M6×16 螺钉	2		03.0228
5	30351060005	Nut M6 卡扣螺母	4		03.0587
6	54302000098	Cover 配电箱盖	1		02.FGJ.0228
6	20201000695	Cover 配电箱盖	1	250215-	配圆形电量表
7	30251060025	Screw M6×12 螺钉	2		03.0090
8	54302000093	Cover 配电箱盖封板	1		02.FGJ.0222

2.101 Driving Assembly
驱动总成

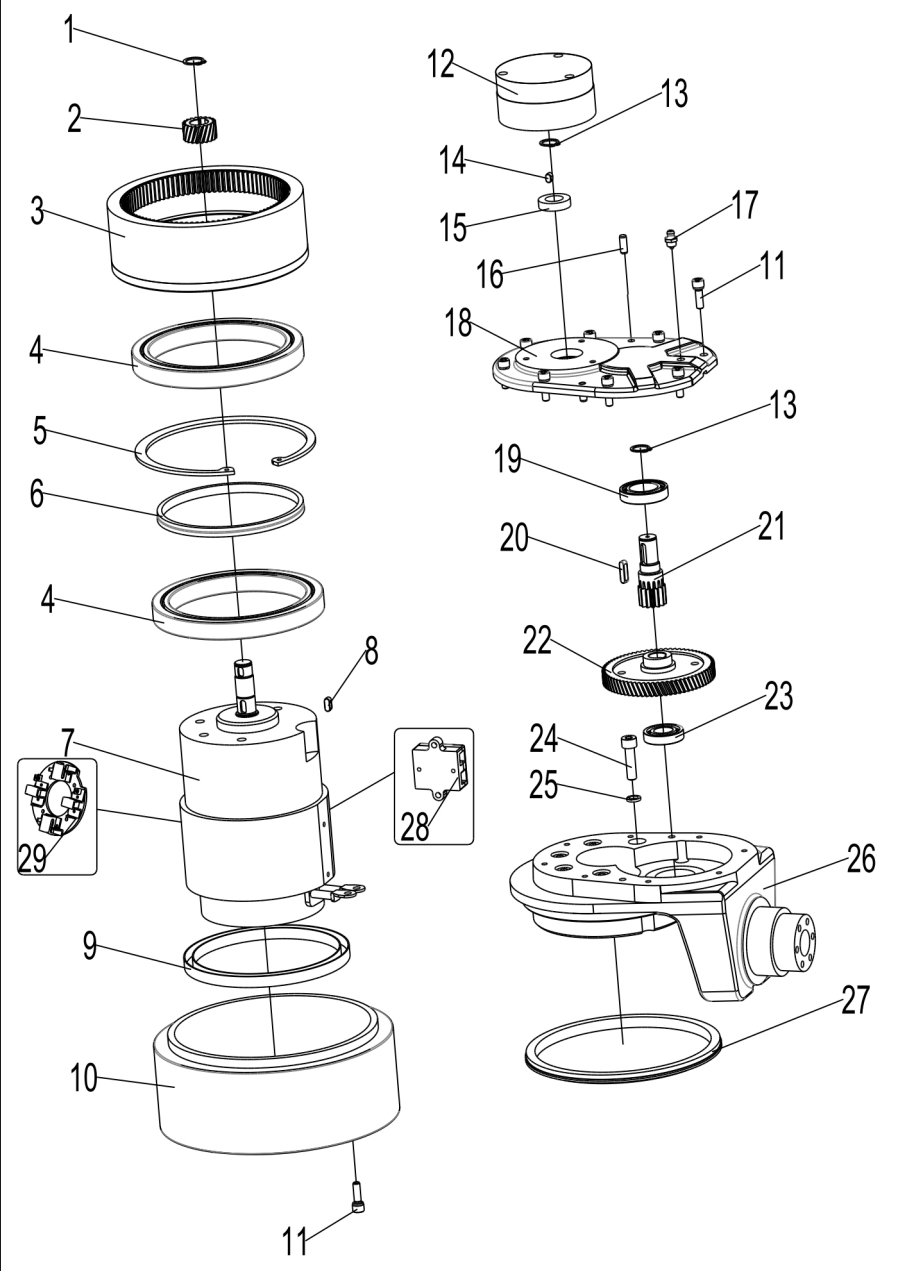

Item 序号	Part No. 代码	Description 名称	Qty 数量	Applied Date 适用日期	Remark 备注
A 01	52101000021	Driving Assembly DC 驱动总成直流	1	-250108	
A 02	52101000116	Driving Assembly DC 驱动总成直流	1	250108-	
A	52101000032	Driving Assembly AC 驱动总成交流	1	250108-	
1	30421160001	Circlip For Shaft Φ16 轴用挡圈	1		03.0062
2	52202120001	Driving Gear 主动斜齿轮	1		02.01.00702
3	52201150005	Internal Gear 内齿轮	1		02.01.00684
4	30701120003	Bearing 61824 轴承	2		02.01.006810
5	30421000002	Circlip For Hole Φ150 孔用挡圈	1		03.0709
6	52105000040	Spacer 隔套	1		02.01.9294
7	70402000022	Motor DC 直流电机	1		02.DJ.00850
7	70401000115	Motor AC 交流电机	1	250108-	
8	30601050003	Flat Key Pin 平键销	1		03.0716
9	30802128001	Oil Seal 油封	1		02.01.3703
10	51241000104	Driving Wheel 驱动轮	1		02.QDL.0272
11	30201060003	Screw M6×20 螺钉	16		03.1180
12	55704000001	Brake Assembly 刹车总成	1		02.01.3596
13	30421150001	Circlip For Shaft Φ15 轴用挡圈	2		03.0061
14	30601050005	Flat Key Pin 平键销	1		03.0975
15	30802016001	Oil Seal 油封	1		03.0719
16	30501060003	Cylindrical Pin Φ6×16 圆柱销	2		03.0439
17	30821008001	Grease Fitting 黄油嘴	1		03.0506
18	52105000041	Gearbox Cover 箱盖	1		02.01.210707
19	30701025001	Bearing 61905 轴承	1		03.90.075
20 01	30601050004	Flat Key Pin 平键销	1	-250108	03.0717
20 02	30601050006	Flat Key Pin 平键销	1	250108-	
21 01	52201150006	Transmission Gear 传动齿轮	1	-250108	02.01.00701
21 02	52201150011	Transmission Gear 传动齿轮	1	250108-	
22 01	52202120004	Driven Gear 被动斜齿轮	1	-250108	02.01.00703

2.101 Driving Assembly
驱动总成

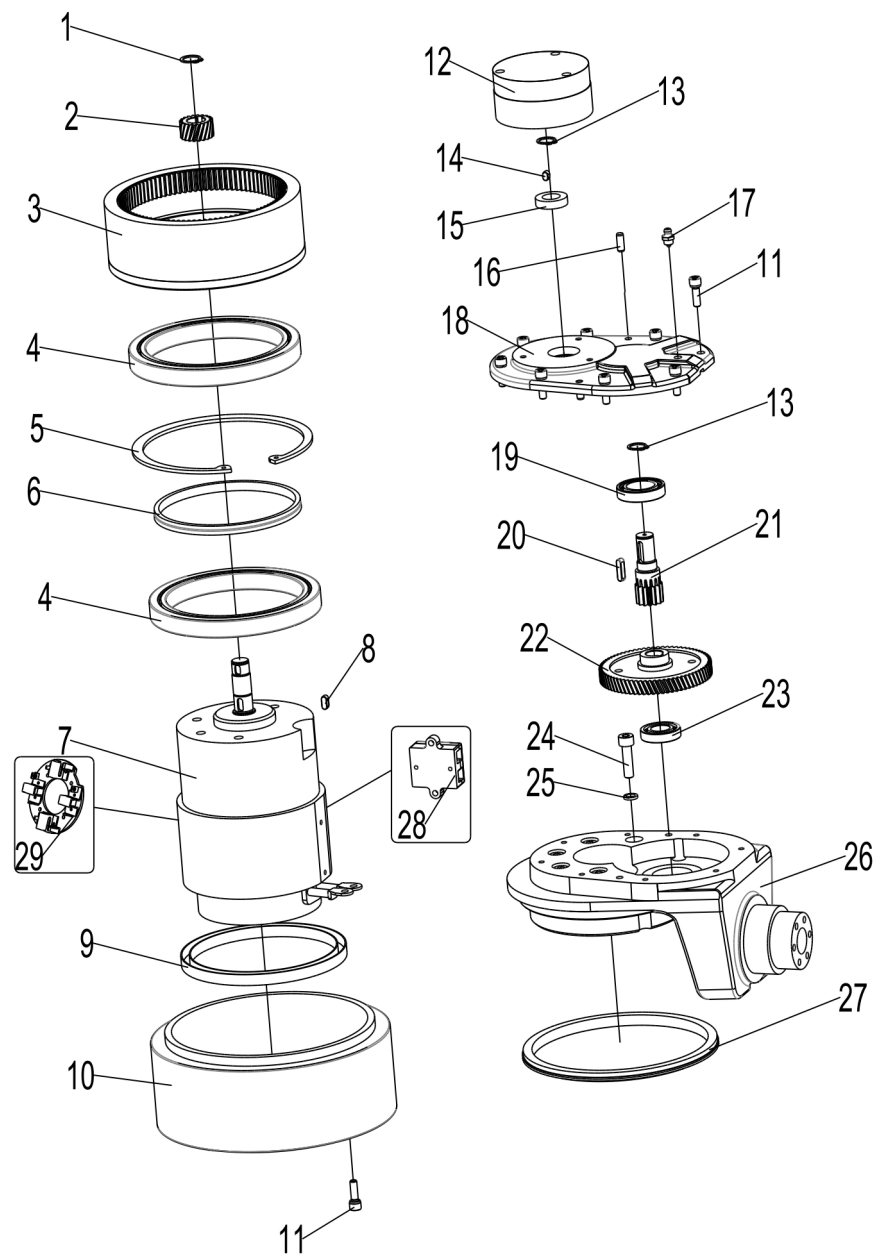

Item 序号	Part No. 代码	Description 名称	Qty 数量	Applied Date 适用日期	Remark 备注
22	02 52202120013	Driven Gear 被动斜齿轮	1	250108-	
23	01 30701017001	Bearing 16003 轴承	1	-250108	03.90.074
23	02 30701017003	Bearing 16003 轴承	1	250108-	
24	30201080006	Screw M8×30 螺钉	5		03.01571
25	30411080002	Spring Washer Φ8 弹垫	5		03.0012
26	01 52105000054	Gearbox 齿轮箱	1	-250108	
26	02 52105000070	Gearbox 齿轮箱	1	250108-	
27	30802155001	Big Oil Seal 大油封	1		02.01.3681
28	70431000052	Motor Junction Box 电机接线盒	1		02.01.0284
29	70431000002	Brush 碳刷	1		19.0526
29	70431000003	Brush 碳刷	1		

2.201 Caster Assembly
平衡轮组件

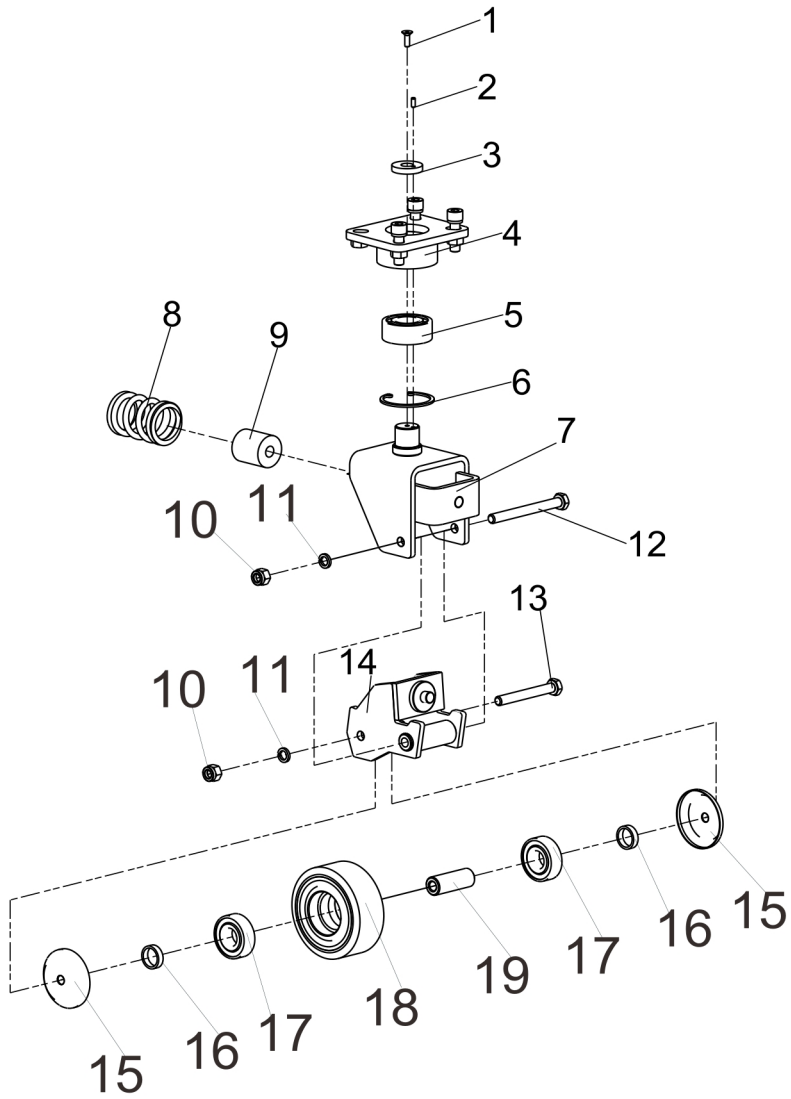

Item 序号	Part No. 代码	Description 名称	Qty 数量	Applied Date 适用日期	Remark 备注
A	51231000029	Caster Components 平衡轮组件	2	-250401	
1	30251050016	Screw M5×16 螺钉	2	-250401	03.0085
2	30501040001	Cylindrical Pin Φ4×10 圆柱销	2	-250401	03.0579
3	20201000240	Blocking Plate 挡片	2	-250401	30.07.079
4	20101010075	Up Wheel Frame 上轮架	2	-250401	33.016.0003
5	30706025003	Bearing 3205A 轴承	2	-250401	03.90.001
6	30421520002	Circlip For Hole Φ52 孔用挡圈	2	-250401	03.00160
7	20101010021	Down Wheel Frame 下轮架	2	-250401	33.005.0015
8	50401000051	Spring 弹簧	2	-250401	02.01.21131
9	50406000002	Elastic Body 弹性体	2	-250401	03.04400
10	30311100001	Nut M10 螺母	4	-250401	03.0243
11	30411100002	Spring Washer Φ10 弹垫	4	-250401	03.0014
12	30101100022	Bolt M10×100 螺栓	2	-250401	03.03641
13	30101100018	Bolt M10×80 螺栓	2	-250401	30.35.ZC.220
14	20101010211	Wheel Frame 小轮架	2	-250401	33.2354
15	20201000529	Dust Gland 防尘盖	4	-250401	30.01.17781
16	20201000526	Washer 垫圈	4	-250401	30.01.1778
17	30701020007	Bearing 6204 轴承	4	-250401	03.90.057
18	51241000032	Balance Wheel Φ100×40 平衡轮	2	-250401	02.LZ.0127
19	50301100002	Shaft Sleeve 轴套	2	-250401	30.01.1277

2.201 Caster Assembly
平衡轮组件

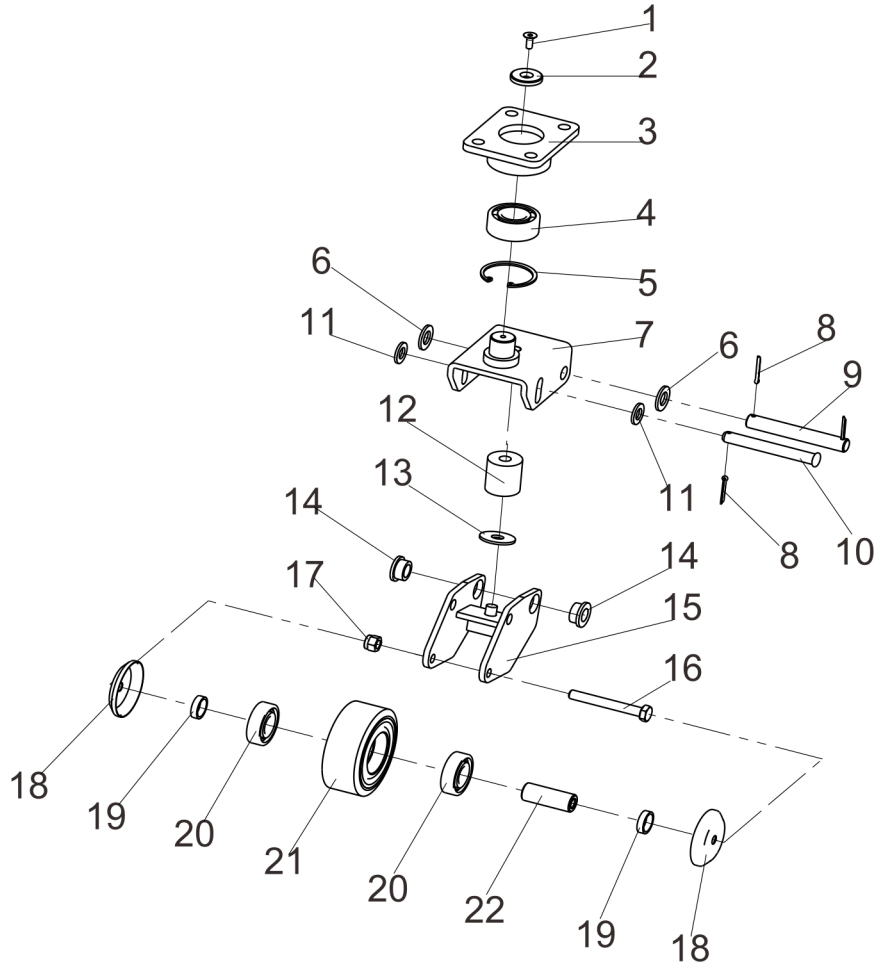

Item 序号	Part No. 代码	Description 名称	Qty 数量	Applied Date 适用日期	Remark 备注
A	20301020001	Caster Assembly 平衡轮组件	2	250401-	
1	30251060029	Screw M6×16 螺钉	2	250401-	
2	20201000463	Connecting Piece 转轴连接片	2	250401-	
3	51251000010	Up Wheel Frame 上轮架	2	250401-	
4	30706025003	Bearing 3205A 轴承	2	250401-	
5	30421520002	Circlip For Hole Φ52 孔用挡圈	2	250401-	
6	30401140003	Washer Φ14 垫圈	4	250401-	
7	20101010226	Down Wheel Frame 下轮架	2	250401-	
8	30511032002	Cotter Pin Φ3.2×25 开口销	6	250401-	
9	50101150002	Rotation Shaft 转轴	2	250401-	
10	30511120001	Pin Shaft 销轴	2	250401-	
11	30401120001	Washer Φ12 垫圈	4	250401-	
12	50406000002	Elastomer 弹性体	2	250401-	
13	50301125002	Gasket 垫片	2	250401-	
14	50301220002	Ring Gasket 衬圈	4	250401-	
15	51251000006	Whirling Arm 旋转臂	2	250401-	
16	30101100018	Bolt M10×80 螺栓	2	250401-	
17	30311100001	Nut M10 螺母	2	250401-	
18	20201000529	Dust Cover 防尘盖	4	250401-	
19	20201000526	Washer 垫圈	4	250401-	
20	30701020007	Bearing 6204 轴承	4	250401-	
21	51241000032	Balance Wheel 平衡轮	2	250401-	
22	50301100002	Shaft Sleeve 轴套	2	250401-	

3.101 Handle Assembly
手柄总成

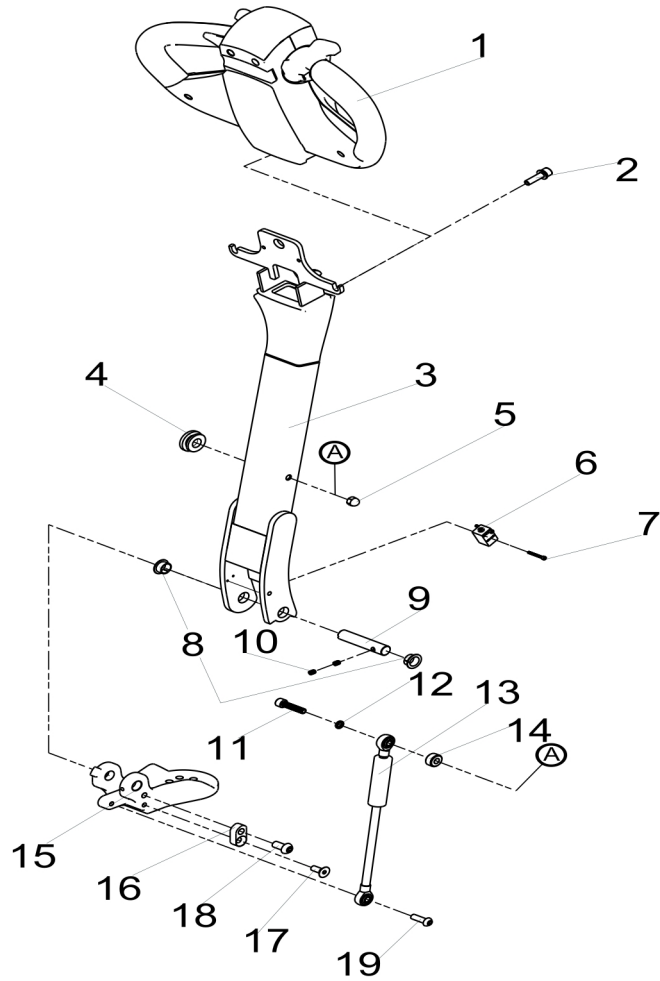

Item 序号	Part No. 代码	Description 名称	Qty 数量	Applied Date 适用日期	Remark 备注
1	71501000002	Control Pod Assembly I 手柄头总成 I	1		02.SB.31780
1	71501000001	Control Pod Assembly II 手柄头总成 II	1		配圆形电量表
2	30201080022	Screw M8×20 螺钉	2		03.0817
3	01 55221000076	Handle Bar 手柄杆	1	-220811	
3	02 55221000050	Handle Bar 手柄杆	1	220811-	
4	54316000016	Shock Absorbers 防震垫	1		02.01.2127
5	30311080001	Nut M8 螺母	1		03.0244
6	70109000001	Proximity Switch 接近开关	1		19.0780
7	30201030004	Screw M3×25 螺钉	2		03.01301
8	54001000008	Bushing Φ18×16×10 带肩复合套	2		03.0452
9	50101160007	Shaft 关节轴	1		40.11.065
10	30221060006	Screw M6×8 螺钉	2		03.0270
11	30201080032	Screw M8×35 螺钉	1		03.0158
12	30411080002	Spring Washer Φ8 弹垫	1		03.0012
13	50407000019	Gas Spring 气弹簧	1		02.QTH.3398
14	50301090003	Spacer 隔套	1		40.11.066
15	20201000253	Joint Seat 关节座	1		30.16.0001
16	20201000134	Limit Block 限位块	1		40.12.031
17	30251080028	Screw M8×20 螺钉	1		03.0092
18	30201100022	Screw M10×20 螺钉	1		03.0163
19	30201080024	Screw M8×25 螺钉	1		03.01562

3.2 Control Pod Assembly I
手柄头总成 I

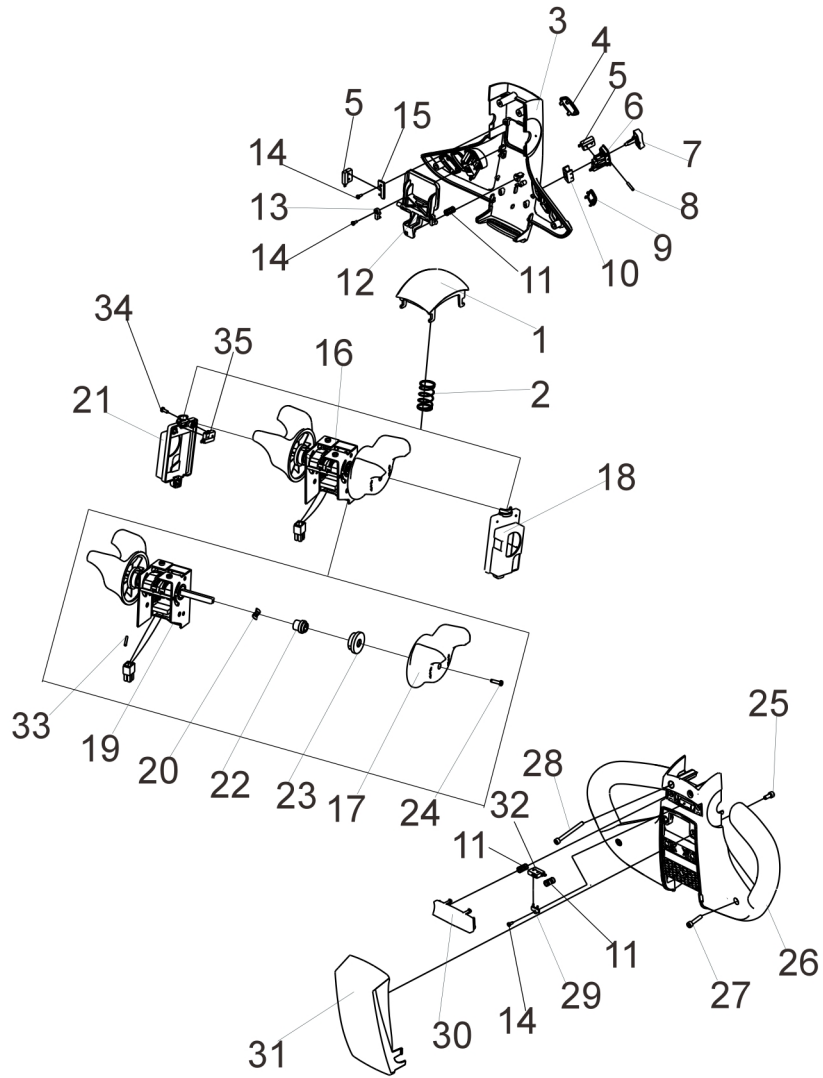

Item 序号	Part No. 代码	Description 名称	Qty 数量	Applied Date 适用日期	Remark 备注
A	71501000002	Control Pod Assembly I 手柄头总成 I	1		02.SB.31780
1	71511000015	Belly Switch 肚皮开关	1		16.0038
2	71511000016	Spring 弹簧	1		03.0725
3	71511000001	Upper Cover 上盖	1		02.01.31770
4	71511000017	Electricity Meter 电量表	1		03.0760
5	70103000006	Micro Switch 微动开关	7		
6	71511000007	Lift Button Base 升降按钮底座	2		02.01.317718
7	71511000004	Lift Button 升降按钮	2		02.01.317721
8	71511000017	Cylindrical Pin $\Phi 3 \times 17$ 圆柱销	2		03.0760
9	71511000014	Button Plug 按钮堵头	3		02.01.317725
10	73109000011	Fixing Sleeve 固定套	2		30.01.3427
11	71511000018	Spring 弹簧	3		03.0726
12	71511000005	Horn Button 喇叭按钮	1		02.01.317723
13	71511000345	Button Clip 按钮卡子	2		02.01.317724
14	30231030002	Screw 螺钉	5		02.SB.PJ.0012
15	71511000107	Install The Card 安装卡	1		02.SB.PJ.0006
16	70132000010	Accelerator Assembly 加速器总成	1		
17	71511000115	Knob 旋钮	2		02.SB.PJ.0027
18	71511000013	Bracket Right 支架右	1		30.01.3424
19	70132000001	Accelerator 加速器	1		
20	30431080001	Wave Washers 波形垫圈	2		03.0735
21	71511000012	Bracket Left 支架左	1		30.01.3423
22	71511000112	Shaft Sleeve 轴内套	2		30.01.3426
23	71511000113	Shaft Jacket 轴外套	2		02.SB.PJ.0025
24	30211030008	Screw M3 \times 12 螺钉	2		03.05364
25	30201050009	Screw M5 \times 12 螺钉	2		03.0131
26	71511000002	Lower Cover 下盖	1		02.01.31772
27	30201050017	Screw M5 \times 25 螺钉	2		03.01410

3.2 Control Pod Assembly I
手柄头总成 I

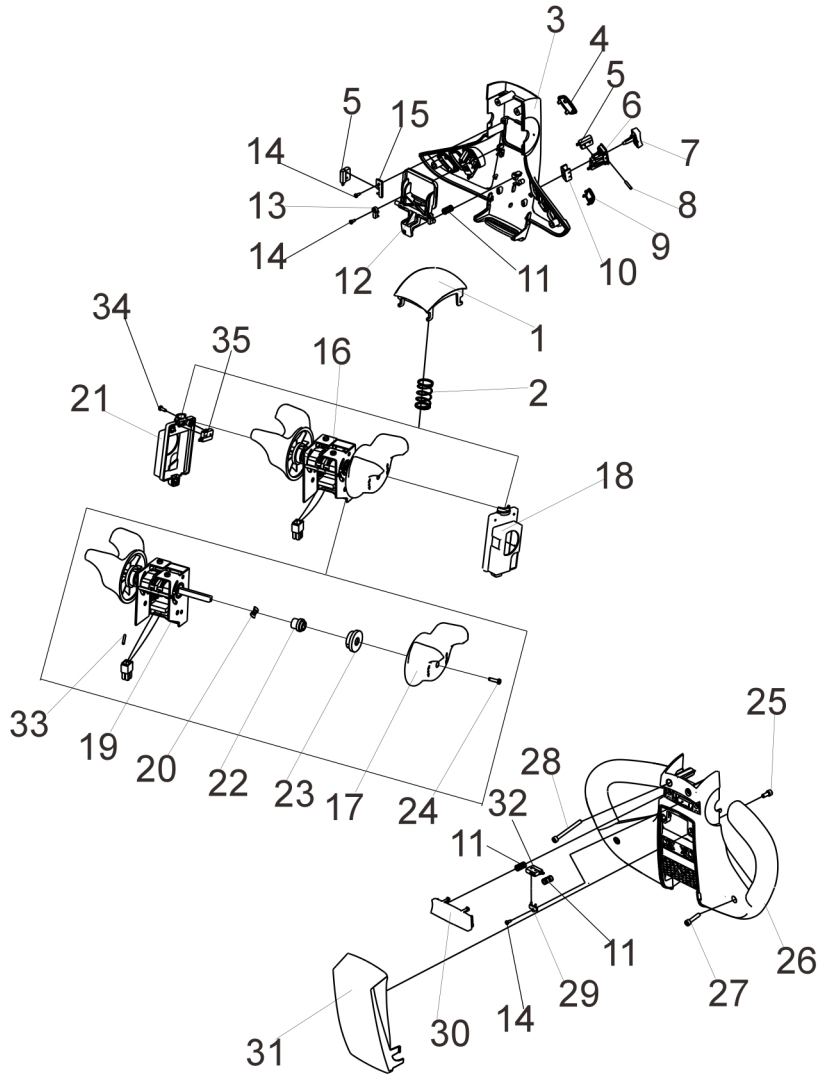

Item 序号	Part No. 代码	Description 名称	Qty 数量	Applied Date 适用日期	Remark 备注
28	30201050019	Screw M5×55 螺钉	2		03.0751
29	71511000109	Install The Card 安装卡	1		02.SB.PJ.0016
30	71511000003	Mode button 模式按钮	1		02.01.317719
31	71511000351	Cover 盖板	1		02.01.31777
32	71511000439	Micro Switch 微动开关	1		
33	71104000050	Inserting pin 插针	2		
34	30231040001	Screw 螺钉	3		
35	70103000006	Micro Switch 微动开关	1		

3.3 Control Pod Assembly II
手柄头总成 II

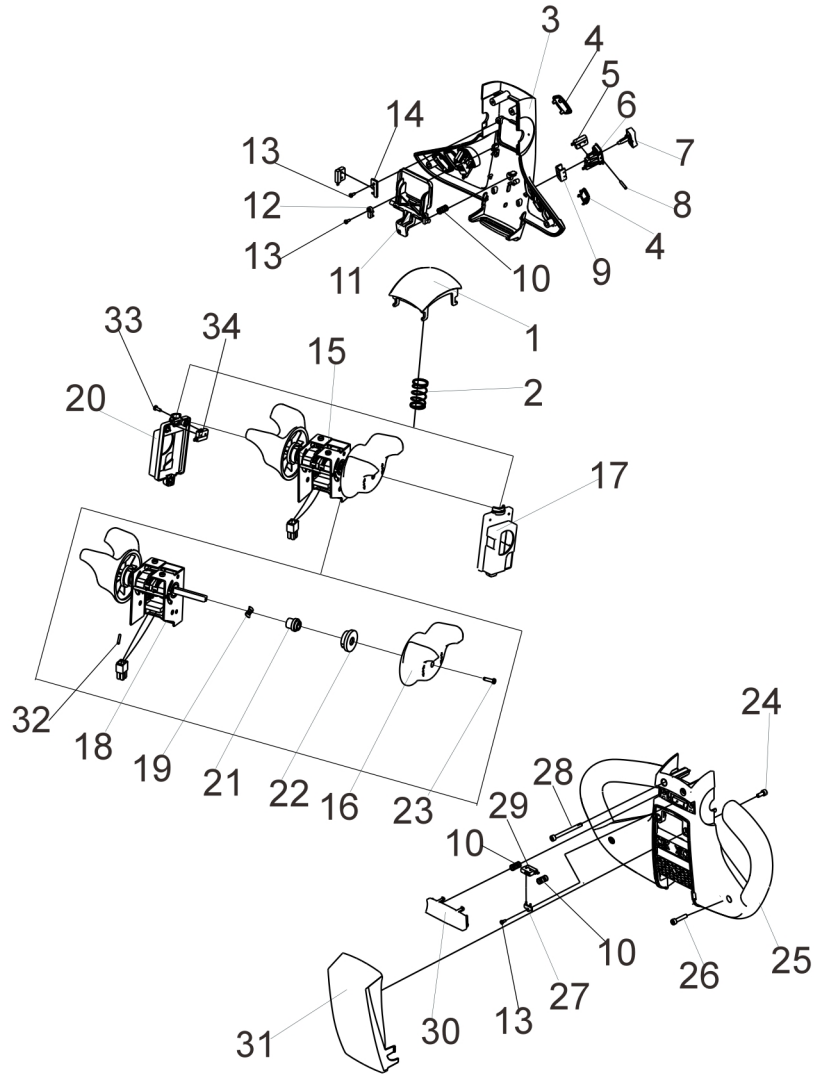

Item 序号	Part No. 代码	Description 名称	Qty 数量	Applied Date 适用日期	Remark 备注
A	71501000001	Control Pod Assembly II 手柄头总成 II	1		配圆形电量表
1	71511000015	Belly Switch 肚皮开关	1		
2	71511000016	Spring 弹簧	1		
3	71511000001	Upper Cover 上盖	1		
4	71511000014	Button Plug 按钮堵头	4		
5	71511000081	Micro Switch 微动开关	7		
6	71511000007	Lift Button Base 升降按钮底座	2		
7	71511000004	Lift Button 升降按钮	2		
8	71511000017	Cylindrical Pin $\Phi 3 \times 17$ 圆柱销	2		
9	73109000011	Fixing Sleeve 固定套	2		
10	71511000018	Spring 弹簧	5		
11	71511000005	Horn Button 喇叭按钮	1		
12	71511000345	Button Clip 按钮卡子	2		
13	30231030002	Screw 螺钉	5		
14	71511000107	Install The Card 安装卡	1		
15	70132000010	Accelerator Assembly 加速器总成	1		
16	71511000115	Knob 旋钮	2		
17	71511000013	Bracket Right 支架右	1		
18	70132000001	Accelerator 加速器	1		
19	30431080001	Wave Washers 波形垫圈	2		
20	71511000012	Bracket Left 支架左	1		
21	71511000112	Shaft Sleeve 轴外套	2		
22	71511000113	Shaft Jacket 轴外套	2		
23	30211030008	Screw M3 \times 12 螺钉	2		
24	30201050009	Screw M5 \times 12 螺钉	2		
25	71511000002	Lower Cover 下盖	1		
26	30201050017	Screw M5 \times 25 螺钉	2		
27	71511000109	Install The Card 安装卡	1		

3.3 Control Pod Assembly II
手柄头总成 II

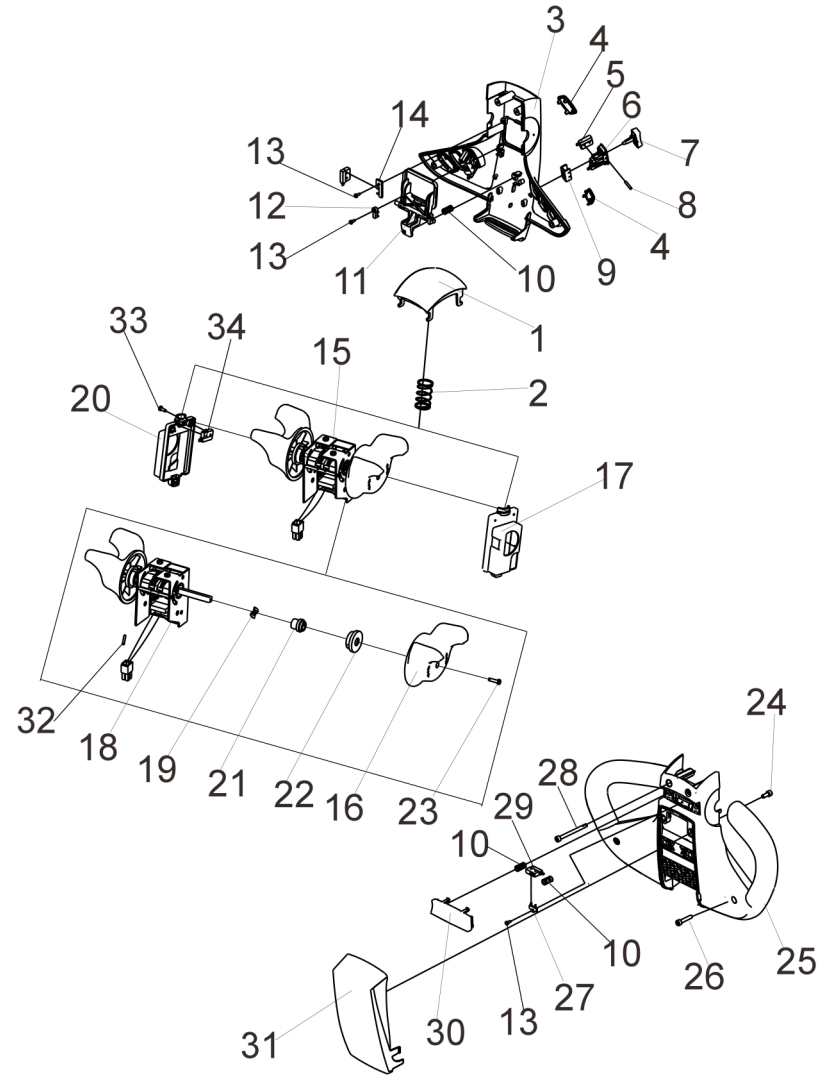

Item 序号	Part No. 代码	Description 名称	Qty 数量	Applied Date 适用日期	Remark 备注
28	30201050019	Screw M5×55 螺钉	2		
29	71511000439	Micro Switch 微动开关	1		
30	71511000003	Mode button 模式按钮	1		
31	71511000351	Cover 盖板	1		
32	71104000050	Inserting pin 插针	2		
33	30231040001	Screw 螺钉	3		
34	70103000006	Micro Switch 微动开关	1		

4.102 Hydraulic Assembly
液压总成

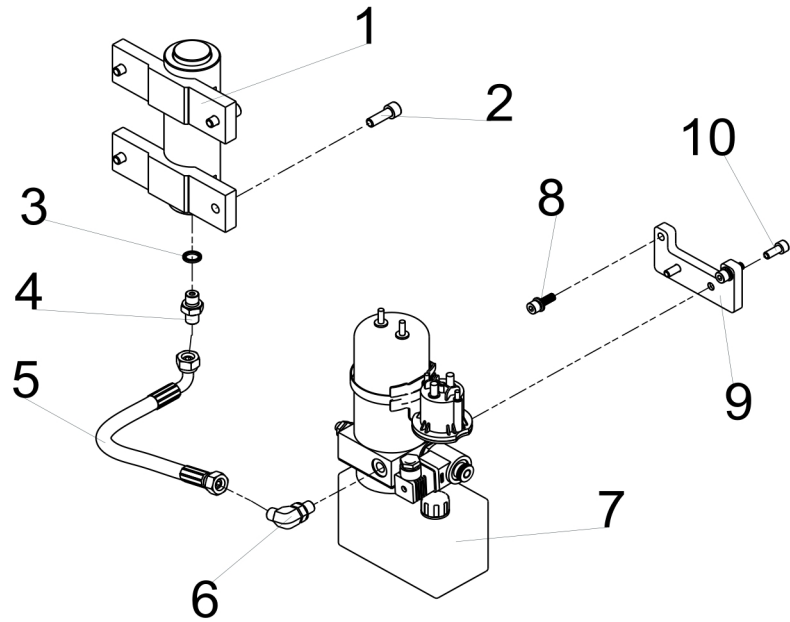

Item 序号	Part No. 代码	Description 名称	Qty 数量	Applied Date 适用日期	Remark 备注
1	40301500071	Oil Cylinder 油缸组件	1		02. YG. 20567
2	30101100061	Bolt M10×30 螺栓	4		
3	30803014001	Gasket Φ14 密封垫	1		03. 0482
4	01 40201000003	Connector 直接头	1	-250215	02. 01. 2356
4	02 40201140005	Connector 直接头	1	250215-	
5	01 40101140002	Oil Hose 胶管	1	-250401	05. 0023
5	02 40101140322	Oil Hose 胶管	1	250401-	
6	40202140004	Connector 直角接头	1		02. YYL. 32003
7	40401024020	Power Unit 动力单元	1		02. DLDY. 0131
8	30201080024	Screw M8×25 螺钉	2		03. 01562
9	20201000275	Bracket 固定支架	1		30. 16. 0010
10	30201080022	Screw M8×20 螺钉	2		03. 0817

4.2 Power Unit Assembly
动力单元组件

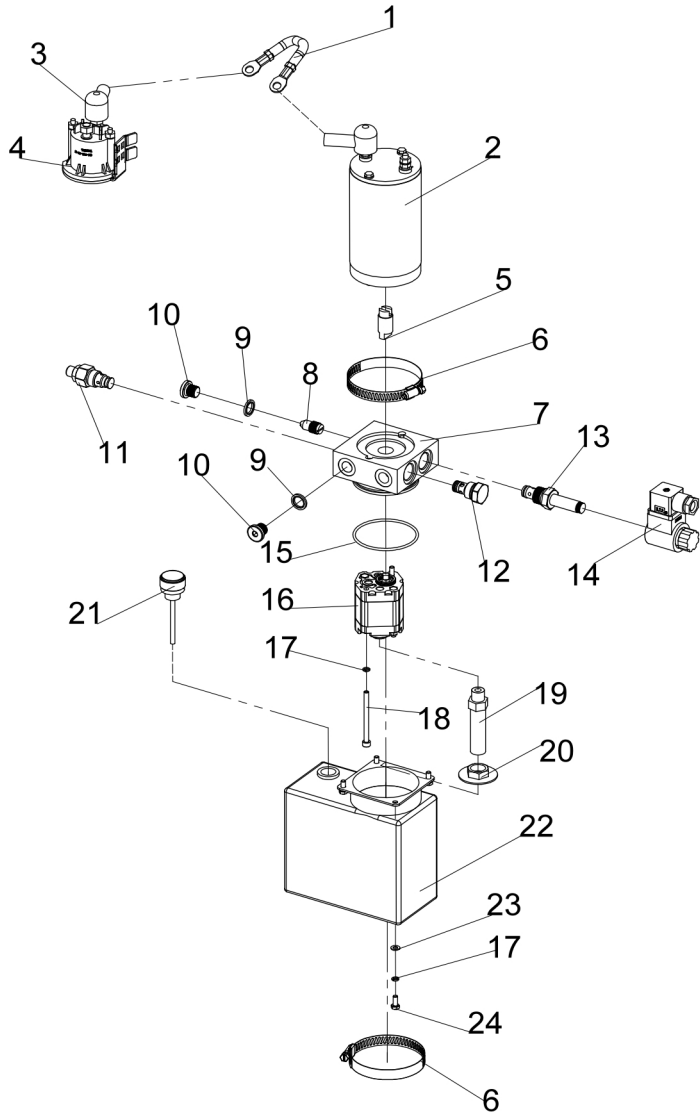

Item 序号	Part No. 代码	Description 名称	Qty 数量	Applied Date 适用日期	Remark 备注
A	40401024020	Hydraulic Line 动力单元	1		02.DLDY. 0131
1	20101030752	Cable 接触器连接线	1		
2	70402000007	Motor 直流提升电机	1		02.DJ. 33618
3	54312000001	Cover 烟斗护套	2		02.01. 2231
4	70303000006	Relay Starter 直流接触器	1		02.01. 2207
5	40411000027	Coupling 联轴器	1		02.01. 9308
6	54012000012	Clamp 抱箍	2		03. 1045
7	40407000008	Adapter 中心块	1		02.01. 9342
8	40405000012	Pressure Valve 压力补偿阀	1		02.01. 9384
9	30803013001	Washer Φ13 组合密封垫	2		03. 1067
10	50204000003	Plugs 堵头	2		02.01. 9056
11	40405000056	Relief Valve 溢流阀	1		02.01. 9151
12	40405000038	Check Valve 单向阀	1		02.01. 9028
13	71531000003	Valve Element 电磁阀	1		02.01. 9150
14	71531000031	Electromagnet 电磁阀线圈	1		02.01. 9366
15	30801067001	O-ring O型圈	1		02.01. 9317
16	40402000006	Gear Pumps 齿轮泵	1		02.01. 9059
17	30411050001	Gas Spring Φ5 弹垫	6		03. 00132
18	30201050020	Screw M5×65 螺钉	2		03. 0967
19	40411000044	Suction tube 吸油管	1		
20	40412000005	Filter 滤网	1		02.01. 9310
21	40410000002	Cover 油箱盖	1		02.01. 30420
22	40409000005	Tank 油箱	1		02.01. 9315
23	30401050001	Flat Washer Φ5 平垫	4		03. 00511
24	30101050010	Bolt M5×12 螺栓	4		03. 0911

5.102 Electric Assembly (DC)
电气总成 (直流)

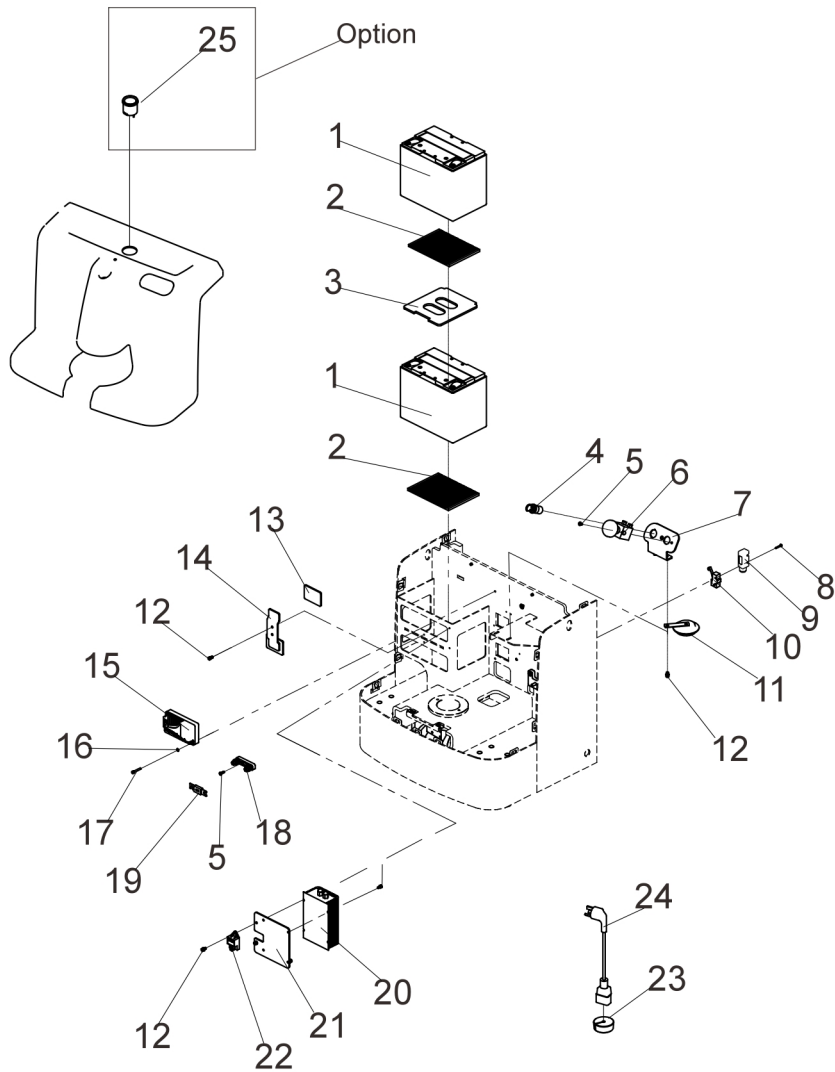

Item 序号	Part No. 代码	Description 名称	Qty 数量	Applied Date 适用日期	Remark 备注
1	70502120023	Battery 24V100AH 铅酸电池	1		02.XDC.220508
1	70503240054	Battery 24V60AH 锂电池	1		02.XDC.2322
1	70503240106	Battery 24V100AH 锂电池	1		
2	54316000023	Non-Slip Mat 防滑垫	2		30.28.0006
3	20201000353	Plate 插板	1		30.16.0041
4	70105000001	Key Switch 钥匙开关	1		02.01.2186
5	30211050003	Screw M5×12 螺钉	2		03.02261
6	70104000005	Emergency Stop Switch 急停开关	1		
7	20201000651	Bracket 急停开关安装板	1		30.01.6370
8	30211040011	Screw M4×25 螺钉	2		03.0223
9	54305000002	Switch Box 开关盒	1		
10	70103000001	Micro Switch 微动开关	1		02.01.2182
11	70222000002	Horn 电喇叭	1		02.01.2218
12	30201060038	Screw M6×12 螺钉	10		03.1231
13	54316000012	Rubber Pads 橡胶垫	2	200817-	30.09.0005
14	20201000372	Bracket 电瓶挡板	1	200817-	30.16.0046
15	70302000004	Controller 1212S-2501 控制器	1		02.KZQ.21511
15	70302000001	Controller D3-2111 控制器	1		02.KZQ.2378
16	30411050001	Lock Washer Φ5 弹垫	2		03.00132
17	30201050012	Screw M5×30 螺钉	2		03.01330
18	70711000001	Fuse Base 熔断器座	1		02.01.3057
19	70701000002	Fuse 保险丝	1		19.03450
20	70411010014	Charger 24V10A 充电器 (铅酸)	1		02.CDQ.330510
20	70412010169	Charger 24V30A 充电器 (锂电)	1		
21	20201000693	Bracket 充电器安装板	1		30.01.6623
22	70307000011	Electric Relay 起升锁止继电器	1		02.01.2216
23	54331000004	Line Seat 线座	1		02.01.312415
24	70422000009	Charger Cable GB 充电线国标	1		

5.102 Electric Assembly (DC)
电气总成 (直流)

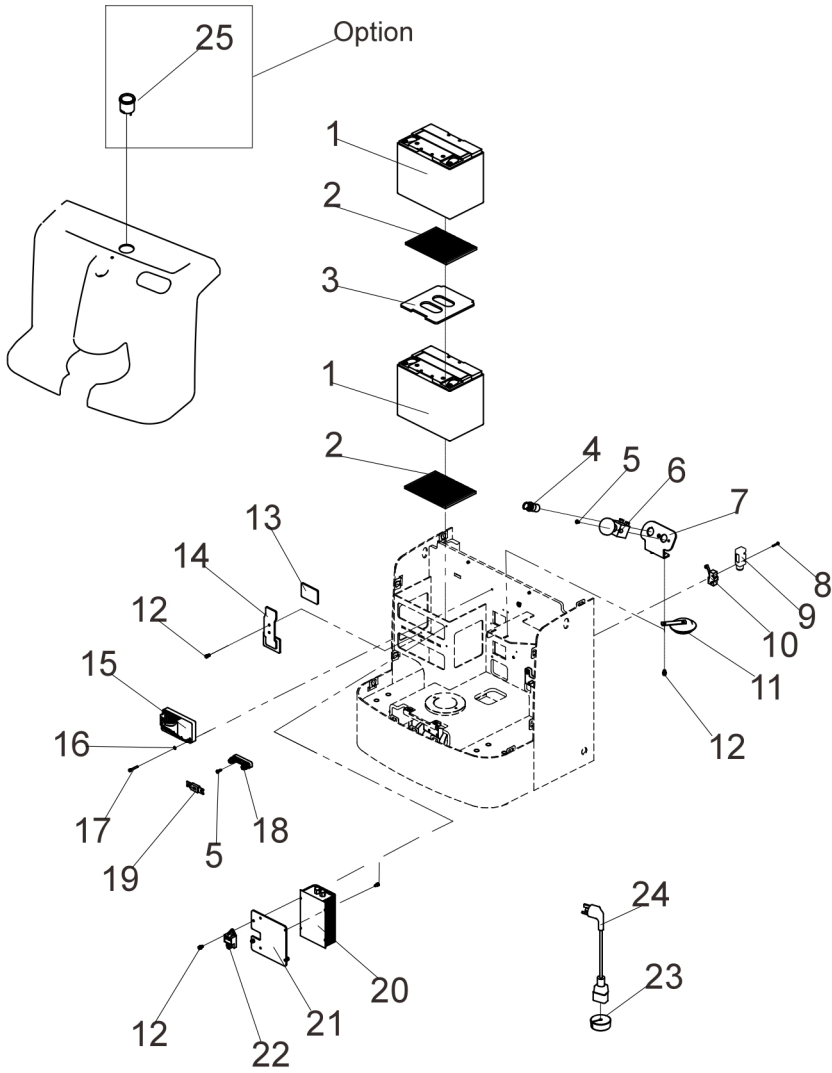

Item 序号	Part No. 代码	Description 名称	Qty 数量	Applied Date 适用日期	Remark 备注
24	70422000010	Charger Cable EU 充电线欧标	1		
24	70422000011	Charger Cable USA 充电线美标	1		
24	70422000012	Charger Cable AUS 充电线意大利标	1		
24	70422000013	Charger Cable UK 充电线英标	1		
24	70422000014	Charger Cable ZA 充电线南非标	1		
24	70422000015	Charger Cable SII 充电线以色列标	1		
24	70422000016	Charger Cable BR 充电线巴西标	1		
24	70422000017	Charger Cable AR 充电线阿根廷标	1		
24	70422000018	Charger Cable AUS 充电线澳大利亚标	1		
24	70422000027	Charger Cable CH 充电线瑞士标	1		
24	70422000001	Charger Cable USA 充电线美标	1		
24	70422000002	Charger Cable ITA 充电线意大利标	1		
24	70422000003	Charger Cable UK 充电线英标	1		
24	70422000004	Charger Cable ZA 充电线南非标	1		
24	70422000005	Charger Cable SII 充电线以色列标	1		
24	70422000006	Charger Cable BR 充电线巴西标	1		
24	70422000007	Charger Cable AR 充电线阿根廷标	1		
24	70422000008	Charger Cable AUS 充电线澳大利亚标	1		
24	70422000019	Charger Cable EU 充电线欧标	1		
24	70422000020	Charger Cable GB 充电线国标	1		
24	70422000025	Charger Cable CH 充电线瑞士标	1		
25	70601000006	Ammeter 圆形电量表	1	250215-	

5.202 Electric Assembly (AC)
电气总成 (交流)

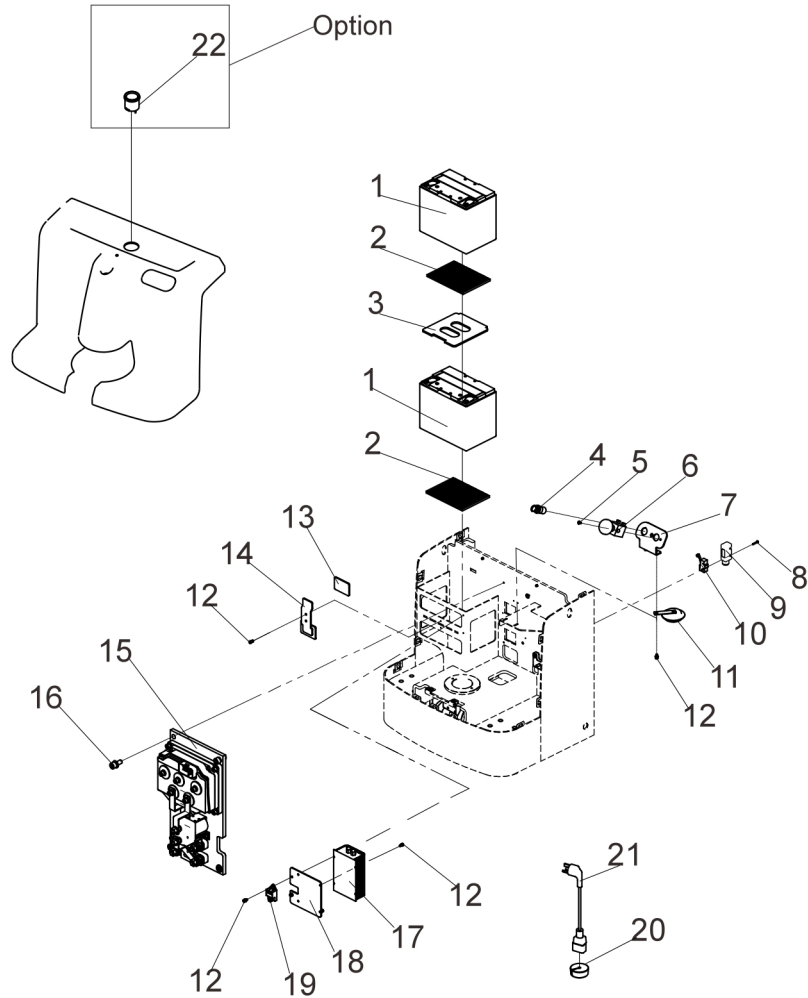

Item 序号	Part No. 代码	Description 名称	Qty 数量	Applied Date 适用日期	Remark 备注
1	70502120023	Battery 24V100AH 铅酸电池	1		02.XDC.220508
1	70503240054	Battery 24V60AH 锂电池	1		02.XDC.2322
1	70503240106	Battery 24V100AH 锂电池	1		
2	54316000023	Non-Slip Mat 防滑垫	2		30.28.0006
3	20201000353	Plate 插板	1		30.16.0041
4	70105000002	Key Switch 钥匙开关	1		02.01.9228
5	30211050003	Screw M5×12 螺钉	2		03.02261
6	70104000004	Emergency Stop Switch 急停开关	1		02.01.9293
7	20201000651	Bracket 急停开关安装板	1		30.01.6370
8	30211040011	Screw M4×25 螺钉	2		03.0223
9	54305000002	Switch Box 开关盒	1		
10	70103000001	Micro Switch 微动开关	1		02.01.2182
11	70222000002	Horn 电喇叭	1		02.01.2218
12	30201060038	Screw M6×12 螺钉	10		03.1231
13	54316000012	Rubber Pads 橡胶垫	2	200817-	30.09.0005
14	20201000372	Bracket 电瓶挡板	1	200817-	30.16.0046
15	70301000012	Electronic Components 电控组件	1		02.DKZC.3368
16	30201080022	Screw M8×20 螺钉	2		03.0817
17	70411010014	Charger 24V10A 充电器 (铅酸)	1		02.CDQ.330510
17	70412010169	Charger 24V30A 充电器 (锂电)	1		
18	20201000693	Bracket 充电器安装板	1		30.01.6623
19	70307000011	Electric Relay 起升锁止继电器	1		02.01.2216
20	54331000004	Line Seat 线座	1		02.01.312415
21	70422000009	Charger Cable GB 充电线国标	1		
21	70422000010	Charger Cable EU 充电线欧标	1		
21	70422000011	Charger Cable USA 充电线美标	1		
21	70422000012	Charger Cable ITA 充电线意大利标	1		
21	70422000013	Charger Cable UK 充电线英标	1		

5.202 Electric Assembly (AC)
电气总成 (交流)

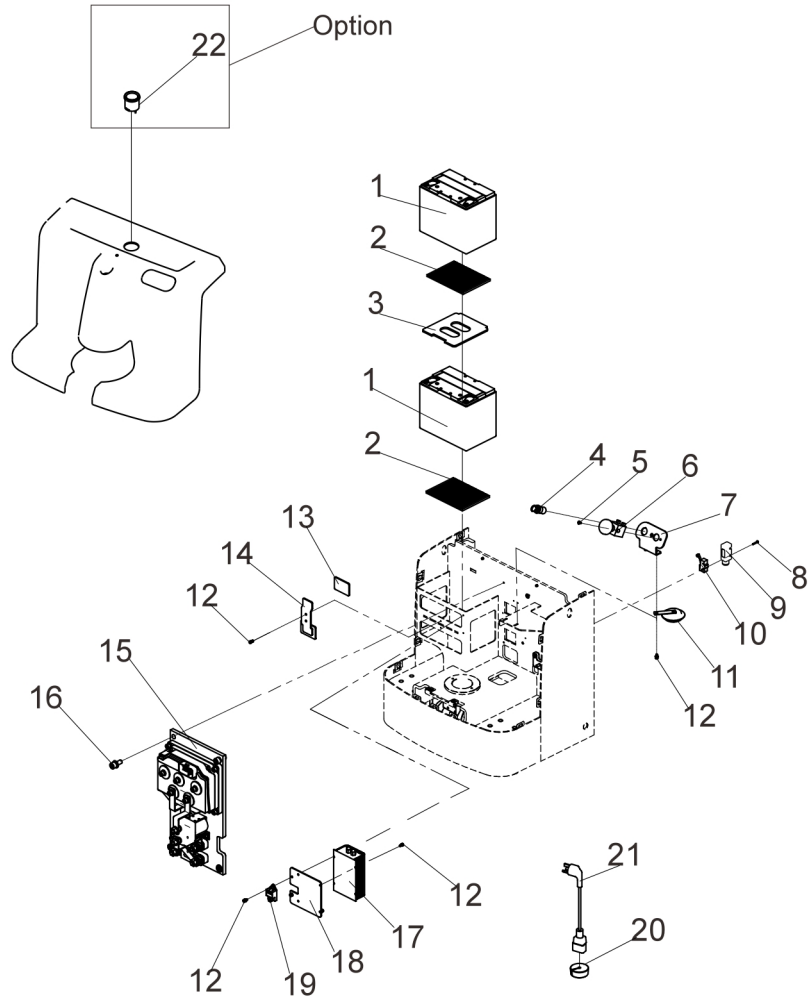

Item 序号	Part No. 代码	Description 名称	Qty 数量	Applied Date 适用日期	Remark 备注
21	70422000014	Charger Cable ZA 充电线南非标	1		
21	70422000015	Charger Cable SII 充电线以色列标	1		
21	70422000016	Charger Cable BR 充电线巴西标	1		
21	70422000017	Charger Cable AR 充电线阿根廷标	1		
21	70422000018	Charger Cable AUS 充电线澳大利亚标	1		
21	70422000027	Charger Cable CH 充电线瑞士标	1		
21	70422000001	Charger Cable USA 充电线美标	1		
21	70422000002	Charger Cable ITA 充电线意大利标	1		
21	70422000003	Charger Cable UK 充电线英标	1		
21	70422000004	Charger Cable ZA 充电线南非标	1		
21	70422000005	Charger Cable SII 充电线以色列标	1		
21	70422000006	Charger Cable BR 充电线巴西标	1		
21	70422000007	Charger Cable AR 充电线阿根廷标	1		
21	70422000008	Charger Cable AUS 充电线澳大利亚标	1		
21	70422000019	Charger Cable EU 充电线欧标	1		
21	70422000020	Charger Cable GB 充电线国标	1		
21	70422000025	Charger Cable CH 充电线瑞士标	1		
22	70601000006	Ammeter 圆形电量表	1	250215-	

5.3 Electronic Components
电控组件

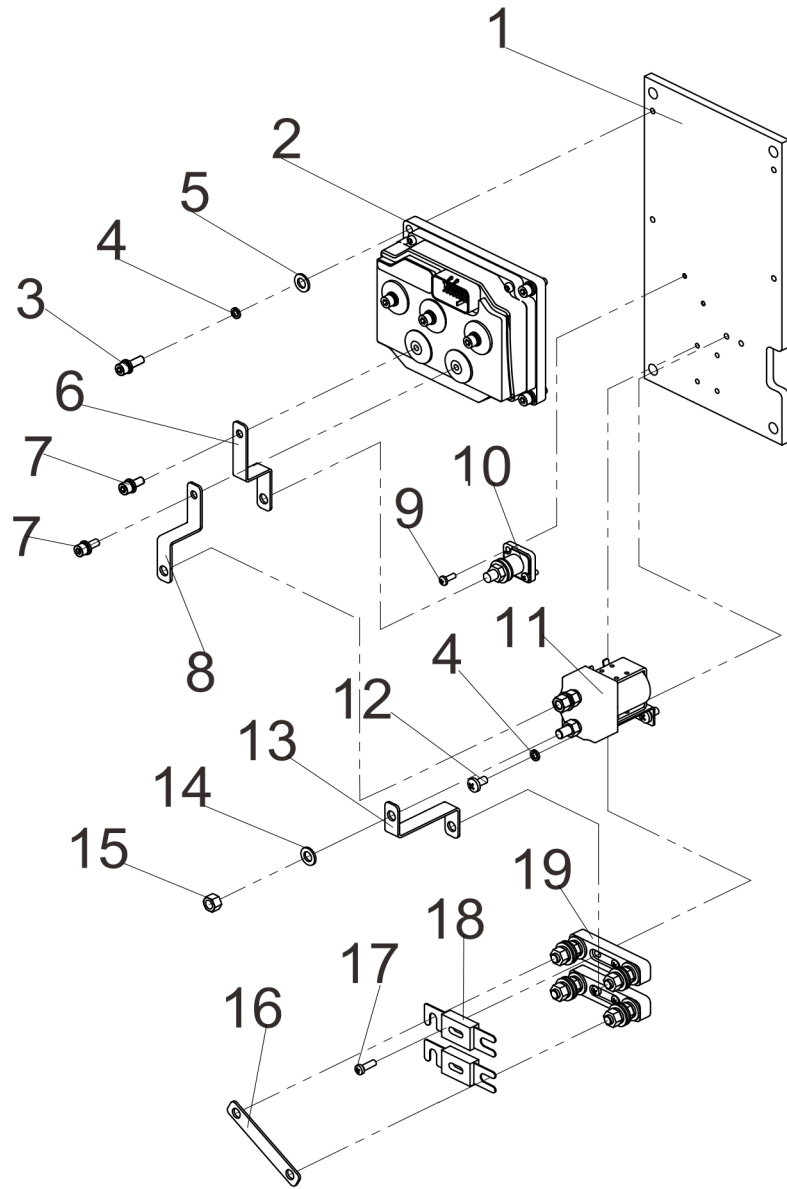

Item 序号	Part No. 代码	Description 名称	Qty 数量	Applied Date 适用日期	Remark 备注
A	70301000012	Electronic Components 电控组件	1		
1	10101020004	Plate 铝板	1		02.01.3330
2	70302000028	Controller 控制器 F2-A	1		02.KZQ.2164
3	30201060021	Screw 螺钉	4		03.0149
4	30411060002	Spring Washer 弹垫	6		03.0011
5	30401060001	Flat Washer 平垫	4		03.00512
6	10101090001	Negative Copper Strip 铜条	1		
7	30201060037	Screw 螺钉	5		03.0934
8	70331000006	Positive Copper Strip 铜条	1		
9	30211040006	Screw 螺钉	2		03.0215
10	70921000001	Wiring Terminal 接线柱	1		16.0543
11	70303000000	Master Contactor 主接触器	1		02.01.21621
12	30211060007	Screw 螺钉	2		03.0227
13	70331000009	Connection Strap 连接片	1		16.0622
14	30401080001	Flat Washer 平垫	2		03.0050
15	30301080001	Nut 螺母	2		03.0258
16	70331000008	Copper Guide Plate 铜导板	1		16.0621
17	30211050003	Screw 螺钉	4		03.02261
18	70701000003	Fuse 保险丝	2		02.01.2000
19	70711000001	Fuse Base 熔断器座	2		02.01.3057

5.5 Wiring Harness Assembly D3-2111

线束总成 D3-2111 (圆形电量表)

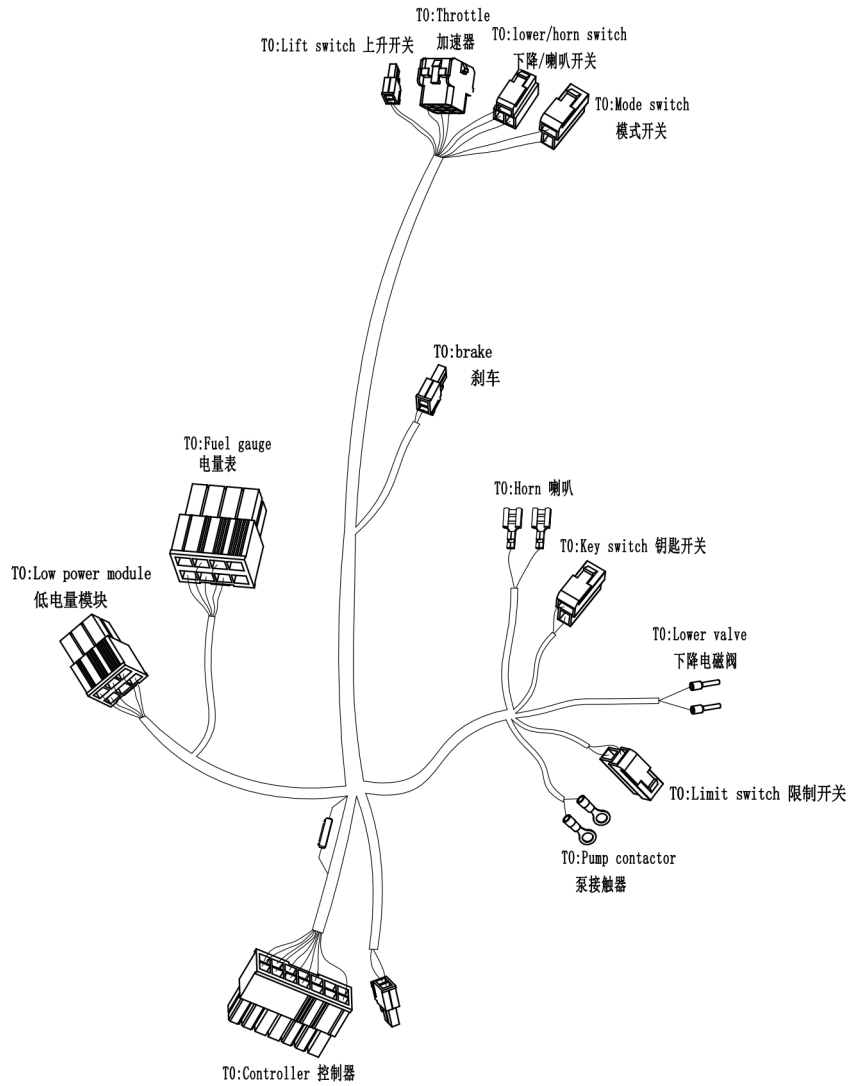

Item 序号	Part No. 代码	Description 名称	Qty 数量	Applied Date 适用日期	Remark 备注
A	20102030574	Control Wire Assembly 控制线组件	1		

5.8 Cable Assembly Lead acid
 电缆总成 铅酸

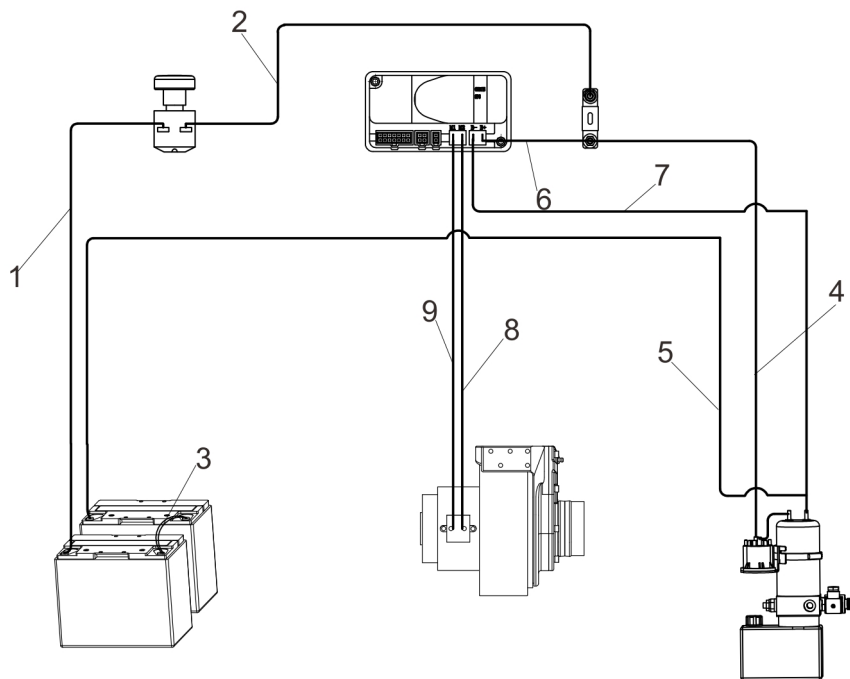

Item 序号	Part No. 代码	Description 名称	Qty 数量	Applied Date 适用日期	Remark 备注
A	20101030386	Cable Assembly 电缆总成	1		
1	20101030387	Battery Cable + 电池正极-急停线	1		
2	20101030388	Stop Cable 急停-保险线	1		
3	20101030395	Battery Cable 电瓶连接线	1		
4	20101030391	Pump Power Cable - 泵电机负线	1		
5	20101030390	Pump Power Cable + 泵电机正线	1		
6	20101030389	Pump Power Cable + 泵电机正极线	1		
7	20101030392	Controller Cable - 控制器负极线	1		
8	20101030393	M1 Cable M1 电机线	1		
9	20101030394	M2 Cable M2 电机线	1		

5.10 Cable Assembly F2-A Lead acid
 电缆总成 F2-A 铅酸

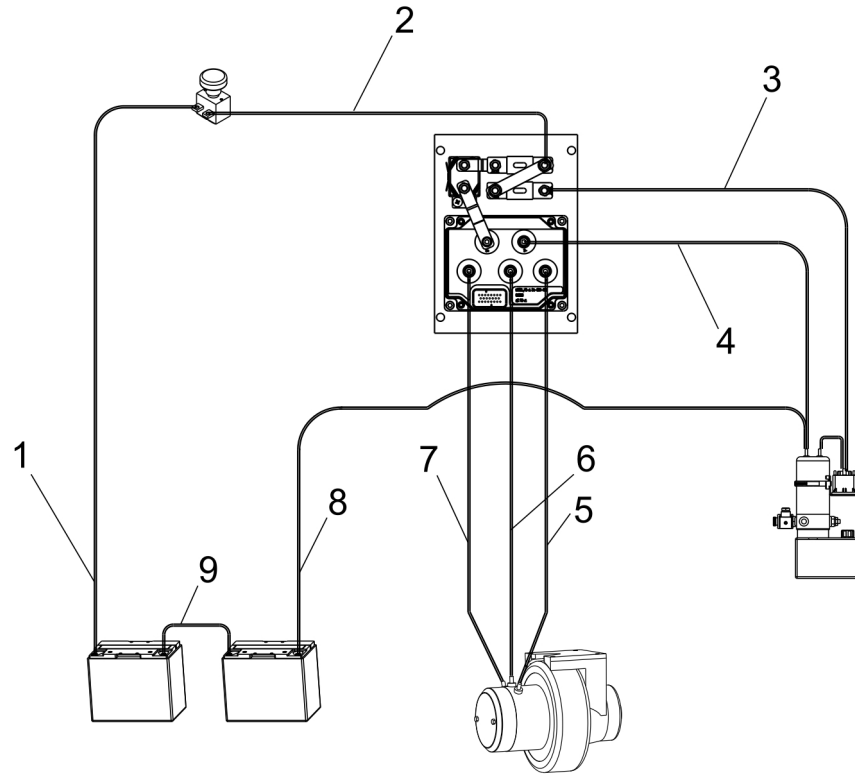

Item 序号	Part No. 代码	Description 名称	Qty 数量	Applied Date 适用日期	Remark 备注
A	20101030373	Cable Assembly 电缆总成	1		
1	20101030374	Battery Cable + 电池正极-急停线	1		
2	20101030374	Stop Cable 急停-保险线	1		
3	20101030376	Pump Power Cable + 泵电机正极线	1		
4	20101030384	Controller Cable - 控制器负极线	1		
5	20101030380	W— Motor Cable 电机 W 相线	1		
6	20101030379	V— Motor Cable 电机 V 相线	1		
7	20101030378	U— Motor Cable 电机 U 相线	1		
8	20101030377	Pump Power Cable - 电池负极-泵线	1		
9	20101030381	Battery Cable 电瓶连接线	1		

5.11 Cable Assembly F2-A
 电缆总成 F2-A 锂电

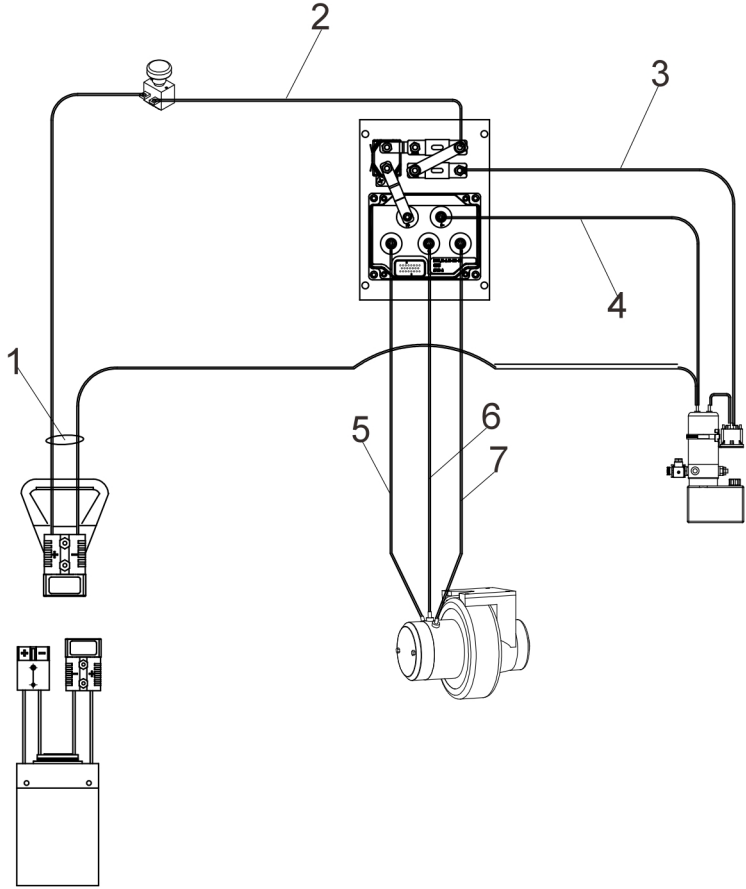

Item 序号	Part No. 代码	Description 名称	Qty 数量	Applied Date 适用日期	Remark 备注
A	20101030997	Cable Assembly 电缆总成	1		
1	20101030998	Vehicle body plug 车体插头	1		
2	20101030375	Stop Cable 急停-保险电缆线	1		
3	20101030376	Pump Power Cable 泵电机正极线	1		
4	20101030384	Controller Cable 泵-电控负极线	1		
5	20101030378	U— Motor Cable 电机U相线	1		
6	20101030379	V— Motor Cable 电机V相线	1		
7	20101030380	W— Motor Cable 电机W相线	1		

零件目录最终由制造商保留解释权！

The power of interpretation of this part catalogue will be preserved by the manufacturer eventually!